

SIMPLIFIED PSO BASED CONTROLLER DESIGN FOR AGC IN DEREGULATED POWER SYSTEMS WITH TCSC, HVDC AND SMES

K. Hari Krishna¹

Assoc. Prof., E.E.E. Dept.
Kallam Haranadha Reddy Inst. Of Tech.,
Guntur, A.P., India
E-mail: harikrishnaketha81@gmail.com

Dr. K. Chandra Sekhar²

PROF., H.O.D. of E.E.E. Dept.
R.V.R. & J.C. College of Engg.,
Guntur, A.P., India
E-mail: cskoritala@gmail.com

Abstract- *This paper presents a suitable mathematical model of Thermal-Hydro-Gas (T-H-G) Automatic Generation Control (AGC) system under deregulated environment. The variable power consumption as well as intermittent load variation may cause large fluctuations on system frequency. To reduce the system oscillations Thyristor Controlled Series Compensation (TCSC), HVDC and AC tie line and Superconducting Magnetic Energy Storage (SMES) can be applied. The system transfer function model comprises thermal, hydro and gas power generations with governor models and system load for studying the dynamic response for small load perturbations along with the model of TCSC, HVDC and AC tie line and SMES are presented. Integral controllers have been considered in both the areas whose optimal values are obtained by minimising the Integral Squared Error (ISE) technique. The particle swarm optimization (PSO) is applied to solve the control problem to achieve the controller parameters and also to optimize the Integral Controllers of two area power system in deregulated environment. An attempt is made in this paper to validate conventionally designed controller parameters to AGC in deregulated power systems to simplify the controller design. The dynamic responses with conventional and deregulated controller parameters are compared. Simulation studies reveal that with the application of the conventionally designed control parameters to the deregulated power systems is valid and gives even better response in some cases*

Keywords- *(Automatic Generation Control; Bilateral Contracts; Power System Control; Deregulation;)*

I. INTRODUCTION

In the traditional power systems, the generation, transmission and distribution are owned by a single entity called a vertically integrated utility (VIU), which supplies power at regulated rates. Such VIUs are

interconnected by tie lines to other VIU's to enhance reliability. Following a load disturbance within a VIU, the frequency of that VIU experiences a transient change, and the feedback mechanism comes into play and generates an appropriate rise/lower signal to the turbine to make the generation follow the load. In steady state, the generation matches with the load, driving the tie line power and frequency deviations to zero.

As deregulation in electric industry is a fast approaching reality, the operation and regulation of the power system in this new type of environment will be different from as it was in the regulated scheme. The deregulated power system consists of GENCOs, TRANSCO, and DISCOs with an open access policy. In the newly emerged structure, the GENCOs may or may not participate in the LFC task. As a matter of fact, Independent system operator leads to make the LFC scheme more reliable. The power system models based on deregulated scenarios has been proposed in [1-15]. Most of the study considers the control problem issue associated with thermal power plants. The LFC study in deregulated structure of three-area power system is presented in [1-3]. The present paper focuses on control problems associated with thermal hydro gas power plants.

Studying automatic generation control (AGC) of power system in presence of flexible ac transmission system (FACTS) devices is an interesting topic that has received much attention in literature. Various FACTS controllers can be applied in series with tie-line of interconnected power systems to control power flow and to damp the inter-area oscillations via designing a supplementary controller. Due to quick dynamic responses, series FACTS devices such as thyristor controlled phase shifter (TCPS) [16-23], static synchronous series compensator (SSSC) [22,24], and interline power

flow controller (IPFC) [25,26] have been employed in power system to attenuate the area frequency and tie-line power oscillations. Thyristor controlled series capacitor (TCSC) as a high-performance and cost-effective series FACTS can be used in power systems as series compensator for fine and secured optimal power flow control in transmission lines [27,28]. The series compensation by TCSC is one of the most economic ways to increase the capability of the line power transfer [29,30]. TCSC controller can be used to mitigate effectively the sub synchronous resonance (SSR) [29].

Fast-acting energy storage system provides storage capacity in addition to the kinetic energy of the generator rotors which can share sudden changes in power requirement and effectively damp electromechanical oscillations in a power system. An attempt to use battery energy storage system (BESS) to improve the LFC dynamics of West Berlin Electric Power Supply has appeared in [32]. The problems like low discharge rate, increased time required for power flow reversal and maintenance requirements have led to the evolution of superconducting magnetic energy storage (SMES) for their applications as load frequency stabilizers. A superconducting magnetic energy storage (SMES) which is capable of controlling active and reactive powers simultaneously [33] is expected as one of the most effective and significant stabilizer of frequency oscillations. The viability of superconducting magnetic energy storage (SMES) for power system dynamic performance improvement has been reported in [34,35].

For the transmission of electric power over long distances, The HVDC transmission is used as an alternate link in the power system scenario, due to its numerous technical and economical advantages [36-40]. Several models of two area or three area AGC systems with AC and DC tie line between different areas are presented in [36]. The parallel combination of AC and DC transmission lines in two area power systems are considered in [36,40]. Effect of HVDC link on the performance of thermal hydro gas AGC system in deregulated power system is studied in this paper.

Several Optimization methods have been proposed for optimization of control parameters of thermal hydro AGC in deregulated power systems. To ease the design effect and thereby improving the performance of controller, the design of fuzzy PI controller by hybrid GA and PSO is presented in [41].

The PSO is population based stochastic optimization technique, inspired by social behaviour of bird flock and gor fish schooling. When an adaptive neuro fuzzy inference and PSO optimization are compared, a better dynamic and steady state response is obtained in [42]. Similarly the design of multi objective PID controller for LFC based on adaptive weighted particle swarm optimization in two-area power system is described in [43,44]. Since PSO is less susceptible to local optima unlike GA, SA, the heuristic evolutionary search technique based hybrid particle swarm optimization has been adopted for determination of optimal PID gains for LFC in four-area power systems having deregulation environments [45].

In the proposed work, in contrast to the existing methodology to design controller for AGC in deregulated power systems an attempt is made in this paper to validate conventionally designed controller parameters to AGC in deregulated power systems. As a part of every control area three types of generators (Thermal, Hydro, Gas) are considered. Focus is made on designing controller for AGC in deregulated power system exclusively in the case of contract violation. Robustness of the controller is validated by comparing its response in controlling frequency, generator output and tie line power when Thyristor Controlled Series Compensation (TCSC), HVDC and AC tie line and Superconducting Magnetic Energy Storage (SMES) are part of system to improve the performance of the system during the load disturbances.

To achieve the controller parameters, the Particle Swarm Optimization (PSO) [22-26] is used to solve the objective function. This paper is organized as follows, In section 2 we first briefly present the AGC model proposed in [16] and which overcomes the limitations of the earlier models proposed in [1-15]. Dynamic model of the Gas generating station is also includes as a part of the considered model. In the section 3 we present the dynamic models of TCSC, HVDC transmission line and SMES used for the improvement of the system response. Particle Swarm Optimization algorithm used for the optimization of controller parameters is discussed in section 4. Simulation results are given in section 5, to highlight the validity of controller parameters designed for conventional power systems used in the deregulated power systems with Thermal-Hydro-Gas AGC systems.

II. CONVENTIONAL AGC SYSTEM

The conventional model, that's being used by several researchers [1-15] is essentially a simple extinction of

traditional Elgerd model [1]. In this AGC model, the concept of disco participation matrix (DPM) is included to the conventional AGC model to incorporate the bilateral load contracts. The DPM gives the extent of consumption of a DISCO from a particulate GENCO. In a power system with m DISCOs and n GENCOs, the DPM is given as

$$DPM = \begin{bmatrix} cpf_{11} & cpf_{12} & | & cpf_{13} & cpf_{14} \\ cpf_{21} & cpf_{22} & | & cpf_{23} & cpf_{24} \\ \hline cpf_{31} & cpf_{32} & | & cpf_{33} & cpf_{34} \\ cpf_{41} & cpf_{42} & | & cpf_{43} & cpf_{44} \end{bmatrix}$$

cpf_{ij} is the "generation participation factor", which shows the participation factor of GENCO i in the load following of DISCO j. the sum of all the entries in a column in this matrix is unity (*i. e.* $\sum_{i=1}^n cpf_{ij} = 1$). Whenever a load demanded by a DISCO changes, it is reflected as a local load in the area to which this DISCO belongs.

These information signals which are not present in the conventional AGC. In [1] introduction of these signals are justified arguing that these signals give an indication regarding which generator has to follow to which DISCO. This expectation is not valid in a deregulated environment.

As there are many GENCOs in each area, AGC signal has to be distributed among them according to their participation in the AGC. "ACE (Area Control Error) participation factors (apf)" are the coefficient factors which distributes the ACE among GENCOs. If there are 'm' number of GENCOs then $\sum_{i=1}^m apf_i = 1$. The block diagram for two area AGC in a deregulated system is shown in figure1. In this model, the scheduled value of steady state tie line power is given as

$$\Delta P_{1-2,scheduled} = (\text{demand of DISCOs in area II from GENCOs in area I}) - (\text{demand of DISCOs in area I from GENCOs in area II})$$

Then the tie line power error is expressed as

$$\Delta P_{1-2,error} = \Delta P_{1-2,actual} - \Delta P_{1-2,scheduled}$$

is used to generate the respective ACE signals as in traditional model. ACE of ith area will be given as

$$ACE_2 = B_2 \Delta F_2 + \Delta P_{1-2,tie,error}$$

Where n is the number of neighbor areas.

The two area AGC system considered has two individual areas connected with a tie line. The deviation in each area frequency is determined by considering the dynamics of the governors, turbines, generators and loads represents in that area. The tie line deviation between the areas is computed as the product of the tie line constant and the frequency deviation difference between two areas. Figure 1 shows the AGC model of the two area system considered. Figure 2 shows dynamic models of the generators in the modeling of each area. The state space representation of AGC model is given by

$$\dot{x} = Ax + Bu + \Gamma p + \beta q \quad (1)$$

Where x is state vector, u is control vector and p is disturbance vector. A, B and Γ and β are the constant matrices associated with state, control, disturbance and bilateral contract vectors respectively. The tie line power in two area AGC is given as

$$\Delta P_{tie12} = \frac{T_{12}}{s} (\Delta f_1 - \Delta f_2) \quad (2)$$

The scheduled power on the tie line in the direction from area I to area II is

$$\Delta P_{1-2,tie,scheduled} = \sum_{i=1}^2 \sum_{j=3}^4 cpf_{ij} \Delta P_{Lj} - \sum_{i=3}^4 \sum_{j=1}^2 cpf_{ij} \Delta P_{Lj}$$

From the AGC model, frequency and tie line power error signals are used to generate the ACE signal in respective area [1]. This ACE of the area is written as

$$ACE_1 = B_1 \Delta f_1 + \Delta P_{tie12-error} \quad (3)$$

$$ACE_2 = B_2 \Delta f_2 + \Delta P_{tie21-error} \quad (4)$$

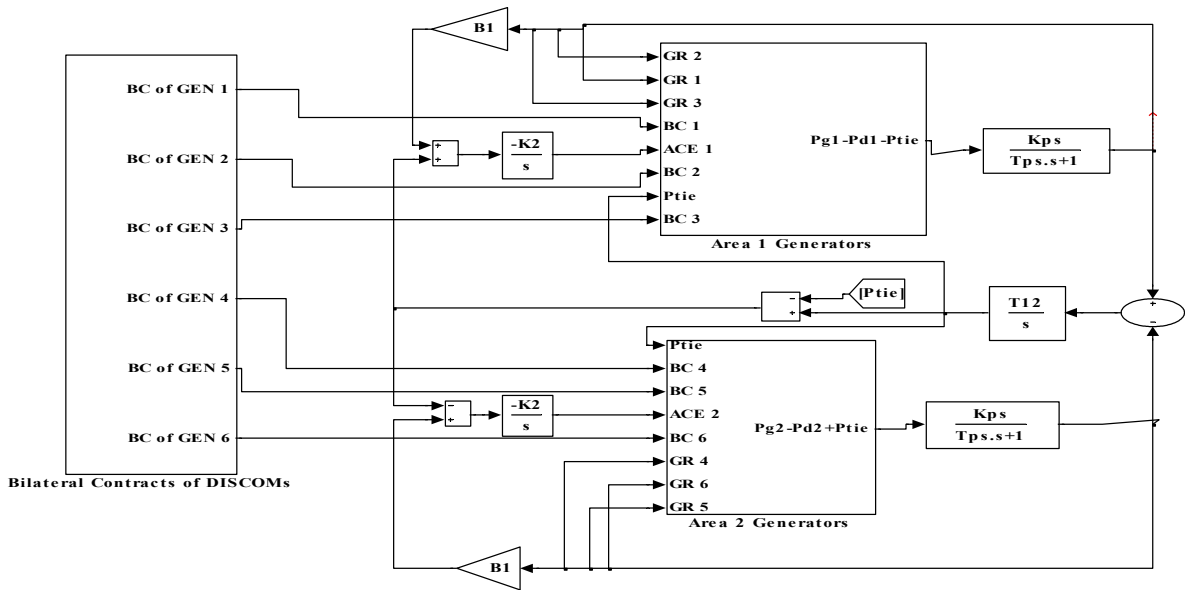

Fig 1 : Modified model of AGC in deregulated power systems with Thermal, Hydro and Gas generators

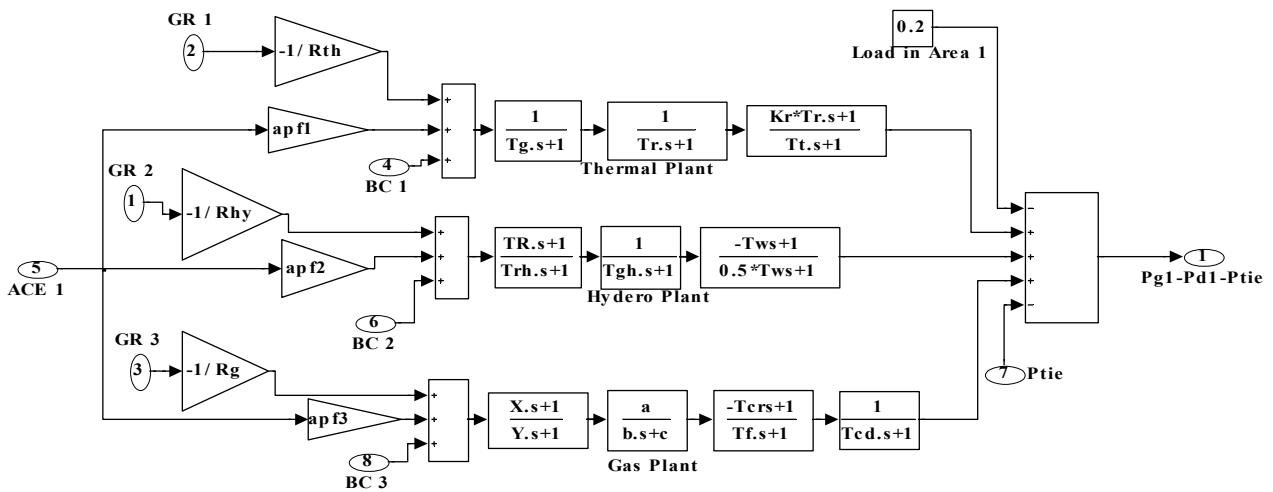

Fig 2. Sub system of the area 1 generators

III. TCSC, HVDC LINK AND SMES

(a). Thyristor Controlled Series Compensation

It is well known that the reactance adjusting of Thyristor Controlled Series Compensator (TCSC) is a complex dynamic process. Effective design and accurate evaluation of the TCSC control strategy depends on the simulation accuracy of this process. Basically a TCSC consists of three components:

capacitor banks, bypass inductor and bidirectional thyristors. The firing angles of the thyristors are controlled to adjust the TCSC reactance in accordance with a system control algorithm, normally in response to some system parameter variations. According to the variation in the thyristor firing angle, this process can be modeled as a fast switch between corresponding reactance offered to the power system. Both capacitive and inductive reactance compensation are possible by proper selection of capacitor and inductor values of the TCSC device. TCSC is considered as a variable reactance, the value of which is adjusted automatically

to constrain the power flow across the branch to a specified value. The variable reactance XTCSK represents the net equivalent reactance of the TCSC, when operating in either the inductive or the capacitive mode [16]. Fig. 3 shows the schematic diagram of a two area interconnected thermal-thermal power system with TCSC connected in series with the tie-line. For analysis, it is assumed that TCSC is connected near to the area 1. Resistance of the tie-line is neglected, since the effect on the dynamic performance is negligible. Further, the reactance to resistance ratio in a practically interconnected power system is quite high. The incremental tie-line power flow without TCSC is given by (5).

$$\Delta P_{Tie12}(s) = \frac{2\pi T_{12}^0}{s} [\Delta F_1(s) - \Delta F_2(s)] \quad (5)$$

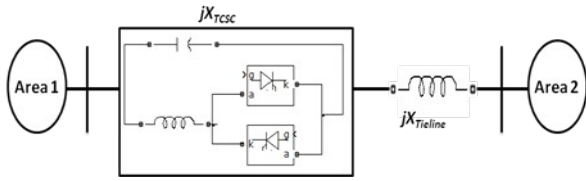

Figure 3 Two-area interconnected power system with TCSC.

In the equation (5), ΔF_1 and F_2 are the system frequency deviations; T_{12}^0 is the synchronizing coefficient without TCSC. The line current flow from area-1 to area-2 can be written as, when TCSC is connected in series with the tie-line

$$I_{12} = \frac{|V_1| \angle \delta_1 - |V_2| \angle \delta_2}{j(X_{12} - X_{TCSC})} \quad (6)$$

where X_{12} and X_{TCSC} are the tie-line and TCSC reactance respectively. It is clear from Fig. 4 that, the complex tie-line power as

$$\begin{aligned} P_{Tie12} - jQ_{Tie12} &= V_1^* I_{12} \\ &= |V_1| \angle (-\delta_1) \left[\frac{|V_1| \angle \delta_1 - |V_2| \angle \delta_2}{j(X_{12} - X_{TCSC})} \right] \end{aligned} \quad (7)$$

Solving the equation (7), the real part,

$$P_{Tie12} = \frac{|V_1||V_2|}{(X_{12} - X_{TCSC})} \text{Sin}(\delta_1 - \delta_2) \quad (8)$$

The tie-line power flow can be represented in terms of % compensation (k_c) as

$$P_{Tie12} = \frac{|V_1||V_2|}{X_{12}(1-k_c)} \text{Sin}(\delta_1 - \delta_2) \quad (9)$$

$$k_c = \frac{X_{TCSC}}{X_{12}}$$

where k_c , percentage of compensation offered by the TCSC. In order to obtain the linear incremental model, Eq. (9) can be rewritten as

$$P_{Tie12} = \frac{|V_1||V_2|}{X_{12}(1-k_c^0)^2} \text{Sin}(\delta_1^0 - \delta_2^0) \Delta k_c + \frac{|V_1||V_2|}{X_{12}(1-k_c^0)} \cos(\delta_1^0 - \delta_2^0) (\Delta \delta_1 - \Delta \delta_2) \quad (10)$$

$$\text{if } J_{12}^0 = \frac{|V_1||V_2|}{X_{12}} \text{Sin}(\delta_1^0 - \delta_2^0) \text{ and } T_{12}^0 = \frac{|V_1||V_2|}{X_{12}} \cos(\delta_1^0 - \delta_2^0)$$

then equation (10) can be written as

$$\Delta P_{Tie12} = \frac{J_{12}^0}{(1-k_c^0)^2} \Delta k_c + \frac{T_{12}^0}{(1-k_c^0)} (\Delta \delta_1 - \Delta \delta_2) \quad (11)$$

$$\Delta \delta_1 = 2\pi \int \Delta F_1 dt \text{ and } \Delta \delta_2 = 2\pi \int \Delta F_2 dt$$

Since

Taking laplace transform of equation (11) and expressed as given by (12)

$$\Delta P_{Tie12} = \frac{J_{12}^0}{(1-k_c^0)^2} \Delta k_c + \frac{T_{12}^0}{(1-k_c^0)} [\Delta F_1(s) - \Delta F_2(s)] \quad (12)$$

From Eq. (12), the tie-line power flow can be regulated by controlling $\Delta k_c(s)$. If the control input signal to TCSC damping controller is assumed to be $\Delta \text{Error}(s)$ and the transfer function of the signal conditioning circuit is

$$k_c = \frac{K_{TCSC}}{1 + sT_{TCSC}}, \text{ The expression is given (13)}$$

$$\Delta k_c(s) = \frac{K_{TCSC}}{1 + sT_{TCSC}} \Delta \text{Error}(s) \quad (13)$$

where K_{TCSC} and T_{TCSC} is the gain and time constant of the TCSC controller respectively. As TCSC is kept near to area-1, frequency deviation ΔF_1 may be suitably used as the control signal $\Delta \text{Error}(s)$, to the TCSC unit to control the percentage incremental change in the system compensation level. Therefore,

$$\Delta k_c(s) = \frac{K_{TCSC}}{1 + sT_{TCSC}} \Delta F_1(s) \quad (14)$$

$$\Delta P_{Tie12} = \left[\frac{J_{12}^0}{(1-k_c^0)^2} \right] \frac{K_{TCSC}}{1 + sT_{TCSC}} \Delta F_1(s) + \frac{2\pi T_{12}^0}{s(1-k_c^0)} [\Delta F_1(s) - \Delta F_2(s)] \quad (15)$$

(b). HVDC Link Design

HVDC link is used to transmit electric power for long distance. Effect of transmission line reactance and charging currents are absent in HVDC transmission system and this makes it possible to have stability with out consideration of line length. HVDC is also preferred for underground and submarine cable transmission over long distance at high voltage. In case of AC cable the temperature rises due to charging current forms a limit for loading. That is beyond certain limit AC cable cannot be used due to thermal limit and the HVAC interconnection between the power systems produces many problems particularly in case of long distance transmission. By the use of HVAC lines, large oscillations are produced which make frequent tripping and increases fault current level. These problems reduce the overall system dynamic performance.

When the HVDC link is used in parallel with the HVAC line, the above problems are reduced and the dynamic performance of the system is also improved. The important features of HVDC transmission lines are fast controllability of line power and improvement of transient stability in HVAC lines. HVDC system has three basic parts such as AC to DC converter station, transmission line and DC to AC converter station. Converters used in both ends are much expensive and HVDC transmission system is economical for long distances and also converters produce a lot of harmonics which may cause interference with communication lines requiring filters which increase the cost. The transfer function model of HVDC link is given by

$$\frac{\Delta P_{dc}}{U_{dc}} = \frac{K_{dc}}{1 + sT_{dc}}$$

Where K_{dc} is gain associated with DC link T_{dc} is time constant of DC link

(c). Capacitive Energy Storage Systems

Superconducting Magnetic Energy Storage (SMES) stores the electric power from grid in the magnetic field of a coil. Superconducting materials with near zero loss are used for coil in SMES. SMESs can store and refurbish huge values of energy almost instantaneously. Therefore the power system can discharge high levels of power within a fraction of a cycle to avoid a rapid loss in the line power. The components of SMES are inductor converter unit, DC super conducting inductor, AD/DC converter and a step down transformer [24]. The stability of a SMES unit is superior to other power storage devices, because all parts of a SMES unit are static. Fig. 4 shows the

schematic diagram of SMES unit in the power system [13]. During normal operation of the grid, the superconducting coil will be charged to a set value (normally less than the maximum charge) from the utility grid. After charged, the superconducting coil conducts current, which supports an electromagnetic field, with virtually no losses. The coil is kept at very low temperature by immersion in a bath of liquid helium. In the present work SMES units are placed in both the control areas to reduce the variation in frequency. Frequency deviation (ΔF) of the control area is given as input to the SMES unit and it gives the electric power supply [ΔP_{SMES}]. to the system accordingly. The controller gains K_{SMES} and the time constant T_{SMES} values are 0.12 and 0.03 s respectively[24].

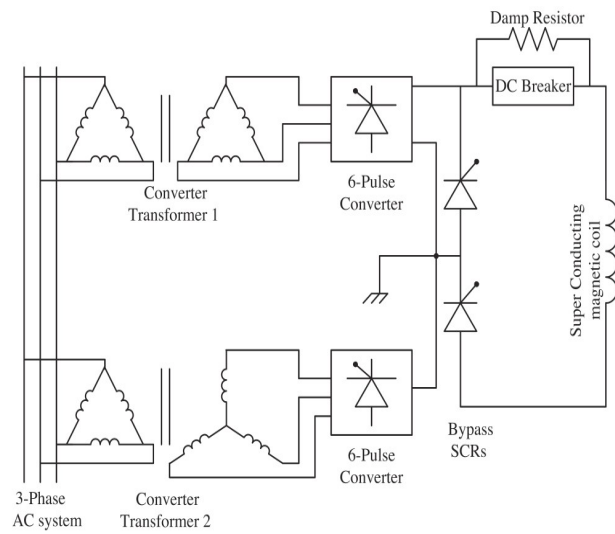

Figure 4 Superconducting Magnetic Energy Storage (SMES) circuit diagram

IV PARTICLE SWARM OPTIMIZATION

Particle swarm optimization is a population-based stochastic optimization algorithm which is first introduced by Kennedy and Eberhart in 1995 [9, 10]. It can be obtained high quality solutions within shorter calculation time and stable convergence characteristics by PSO than other stochastic methods such as genetic algorithm [11]. PSO uses particles which represent potential solutions of the problem. Each particles fly in search space at a certain velocity which can be adjusted in light of proceeding flight experiences. The projected position of i th particle of the swarm x_i , and the velocity of this particle v_i at $(t+1)$ th iteration are defined and updated as the following two equations:

$$v_i^{t+1} = v_i^t + c_1 r_1 (p_i^t - x_i^t) + c_2 r_2 (g_i^t - x_i^t)$$

$$x_i^{t+1} = x_i^t + v_i^{t+1}$$

where, $i = 1, \dots, n$ and n is the size of the swarm, c_1 and c_2 are positive constants, r_1 and r_2 are random numbers which are uniformly distributed in $[0, 1]$, t determines the iteration number, p_i represents the best previous position (the position giving the best fitness value) of the i th particle, and g represents the best particle among all the particles in the swarm. The flowchart of standard PSO algorithm is depicted in Fig.2. At the end of the iterations, the best position of the swarm will be the solution of the problem. It cannot always possible to get an optimum result of the problem, but the obtained solution will be an optimal one. Because of the standard PSO algorithm can fall into premature convergence especially for complex problems with many local optima and optimization parameters, the craziness based PSO algorithm which is particularly effective in finding out the global optimum in very complex search spaces is developed [12]. The main difference between PSO and crazy-PSO is the propagation mechanism to determine new velocity for a particle as follows:

$$v_i^{t+1} = r_2 \text{sign}(r_3) v_i^t + (1-r_3) c_1 r_1 (p_i^t - x_i^t) + (1-r_2) c_2 (1-r_1) (g^t - x_i^t)$$

$$x_i^{t+1} = x_i^t + v_i^{t+1} + P(r_4) \text{sign}(r_4) V_{cr}$$

where p_i is the local best position of particle i , and g_i is the global best position of the whole swarm. r_1 , r_2 , r_3 and r_4 are random parameters distributed uniformly in $[0, 1]$, and c_1 , c_2 are l-named step constants and are taken 2.05 generally. The sign is a function defined as follows for r_3 and r_4 ,

$$\text{sign}(r_3) = \begin{cases} -1 & \leftarrow r_3 \leq 0.05 \\ 1 & \leftarrow r_3 \nrightarrow 0.05 \end{cases}$$

$$\text{sign}(r_4) = \begin{cases} -1 & \leftarrow r_4 \leq 0.05 \\ 1 & \leftarrow r_4 \nrightarrow 0.05 \end{cases}$$

In birds flocking or fish schooling, since a bird or a fish often changes directions suddenly, in the position updating formula, a craziness factor, V_{cr} , is used to describing this behavior. In this study, it is decreased linearly from 10 to 1. $P(r_4)$ is defined as

$$P(r_4) = \begin{cases} 1 & \leftarrow r_4 \leq P_{cr} \\ 0 & \leftarrow r_4 \nrightarrow P_{cr} \end{cases}$$

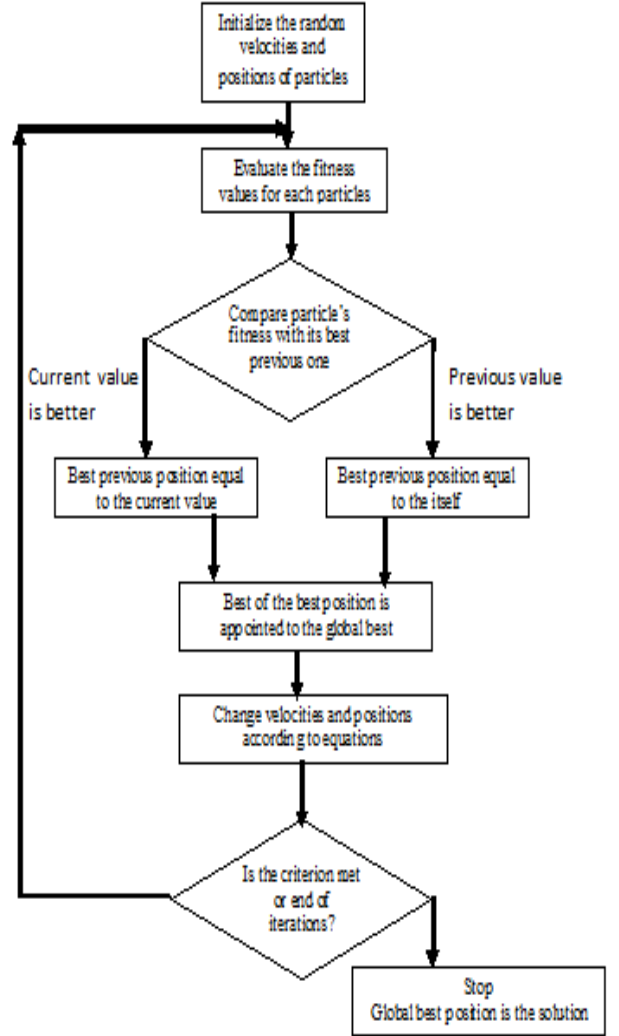

Figure 4 flow chart for particle swarm optimization

where P_{cr} is a predefined probability of craziness and is introduced to maintain the diversity of the particles. It is taken 0.3 in this study. The crazy-PSO algorithm can prevent the swarm from being trapped in local minimum, which would cause a premature convergence and lead to fail in finding the global optimum [12, 13]. The two area system in the deregulated case with identical areas can be optimized with respect to system parameters to obtain the best response. The parameter involved in the feedback is the integral controller (KI). The optimal value of KI depend upon the cost function used for optimization. The integral of squared error criterion (ISE) is used in this case, The objective of this controller is achieved by minimizing a performance index (J). Where J is given as

$$J = \int (\Delta f_1^2 + \Delta f_2^2 + \Delta P_{tie12-error}^2) dt$$

V SIMULATION RESULTS

In contrast to the existing methodology to design controller for AGC in deregulated power systems an attempt is made in this paper to validate conventionally designed controller parameters to AGC in deregulated power systems. The only difference between conventional AGC and deregulated AGC modelling is inclusion of bilateral contracts in deregulated power systems. Bilateral contracts are added with the help of DISCO Participation Matrix (DPM) and it is well known that these bilateral contracts are known disturbances in the system. Generators respond to the changes in DISCO's load according to their participation to the corresponding DISCO, for this load deviation there is no need of an excess controller. Automatic generation control is meant for adjusting the generation for contract violation (Disturbances in load). The contract violation is same in conventional and deregulated power systems, bilateral contracts will affect only initial operating condition of the systems since the instant of disturbance may not be same as contracted load variation.

Focus is made on designing controller for AGC in deregulated power systems exclusively in the case of contract violation and the system is observed to be same as conventional power systems in this case. To make the controller design simple, controller parameters in the conventional power system are used for frequency control and its performance is compared with control parameters in deregulated power system. Robustness of the controller is validated by comparing its response in controlling frequency when Thyristor Controlled Series Compensation (TCSC), HVDC and AC tie line and Superconducting Magnetic Energy Storage (SMES) are part of system to improve the performance of the system during the load disturbances. Two area AGC model is used to illustrate the performance of the present model. To study this model, consider a case where all the DISCOs contract with the GENCOs for power as per the below DPM:

$$DPM = \begin{bmatrix} 0.1 & 0 & 0.2 & 0 \\ 0.2 & 0.1 & 0.1 & 0.5 \\ 0.3 & 0.2 & 0.3 & 0.1 \\ 0.2 & 0.1 & 0 & 0.2 \\ 0.2 & 0.2 & 0.3 & 0.2 \\ 0 & 0.4 & 0.1 & 0 \end{bmatrix}$$

It is assumed that each DISCO demands 0.1pu power from GENCOs as defined in DPM and each GENCO participated in AGC as defined by following apfs:

apf1=0.33, apf2=0.33, apf3=34, apf4=0.33, apf5=0.33, apf6=0.34.

For the DPM mentioned above GENCOs generation must be

$$\Delta P_{m1} = 0.03; \Delta P_{m2} = 0.09; \Delta P_{m3} = 0.09; \Delta P_{m4} = 0.05; \\ \Delta P_{m5} = 0.09; \Delta P_{m6} = 0.05$$

The total local load in area 1

$$\Delta P_{L1,LOC} = \text{Load of DISCO}_1 + \text{Load of DISCO}_2 \\ = 0.2 \text{ pu MW (no un contracted load)}$$

Similarly, the total local load in area 2

$$\Delta P_{L2,LOC} = \text{Load of DISCO}_3 + \text{Load of DISCO}_4 \\ = 0.2 \text{ pu MW (no un contracted load)}$$

Tie line power can be calculated by using the formula given in the above section and is given by 0.01pu as shown in the results. It may happen that a DISCO violates a contract by demanding more power than that specified in the contract. This excess power is not contracted out to any GENCO.

This un contracted power must be supplied by the GENCOs in the same area as the DISCO. It must be reflected as a local load of the area but not as the contract demand. Consider that DISCOs in area 1 are violating contracts and demanding an excess power of 0.01pu.

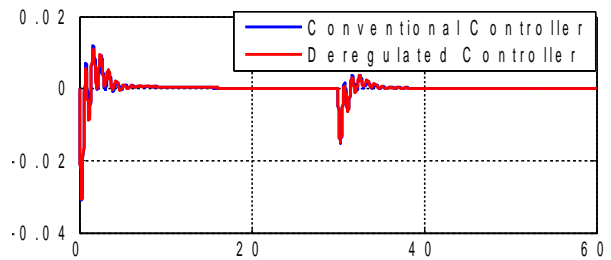

(a)

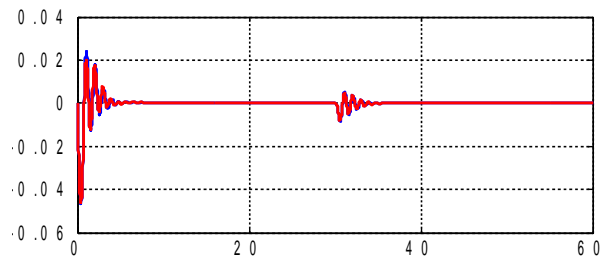

(b)

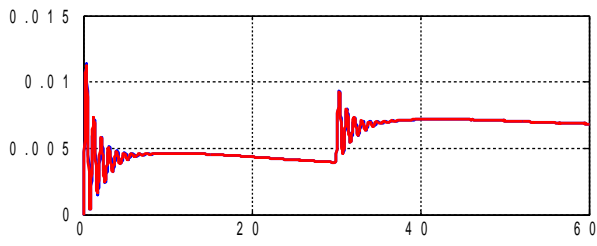

(c)

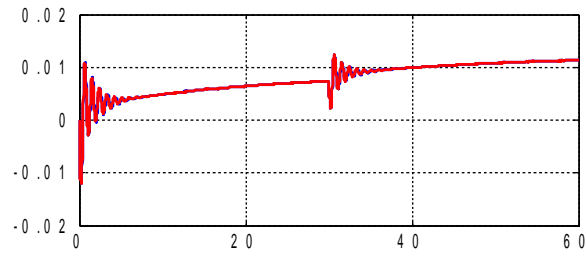

(d)

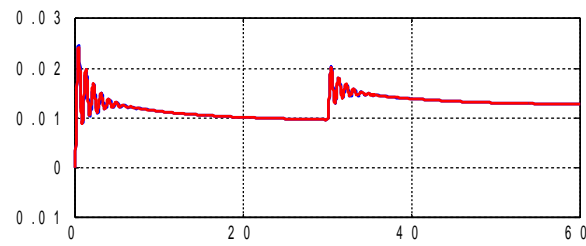

(e)

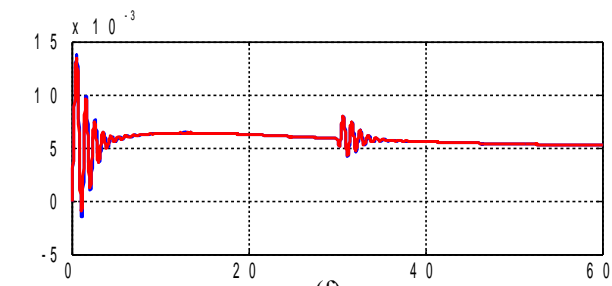

(f)

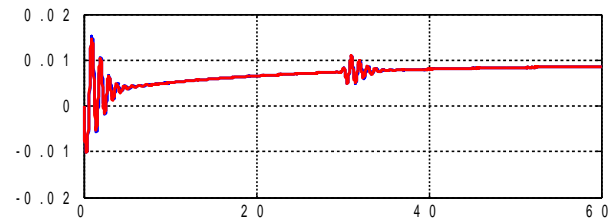

(g)

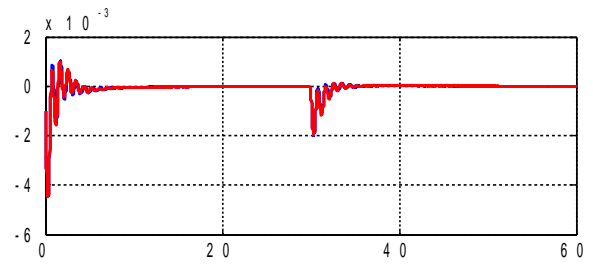
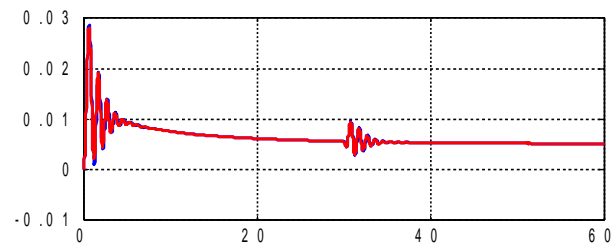

(i)

Fig 6. Response of AGC in deregulated power system with TCSC (a) frequency of area 1, (b) frequency of area 2, (c) power of generator 1, (d) power of generator 2, (e) power of generator 3, (f) power of generator 4, (g) power of generator 5, (h) power of generator 6, (i) tie line power error.

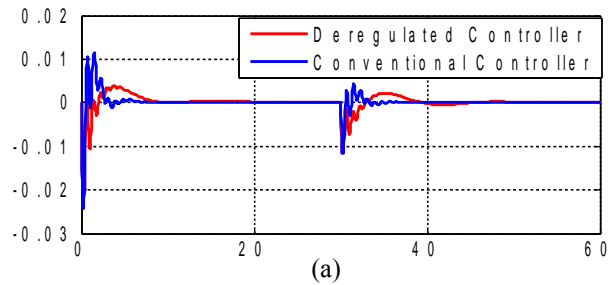

(a)

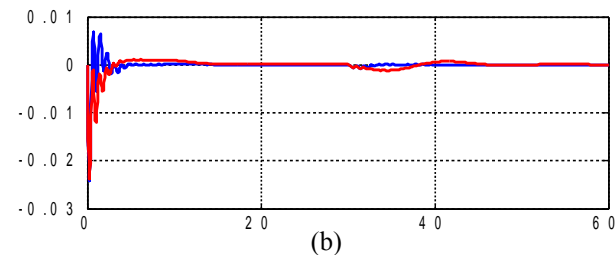

(b)

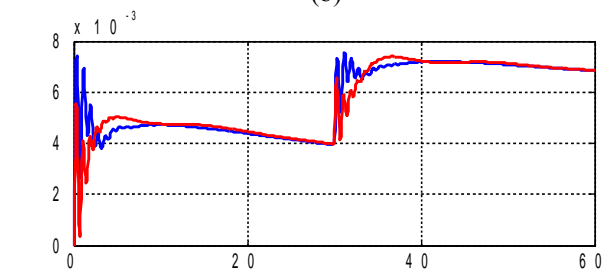

(c)

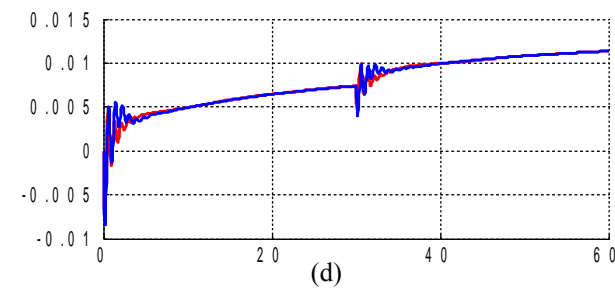

(d)

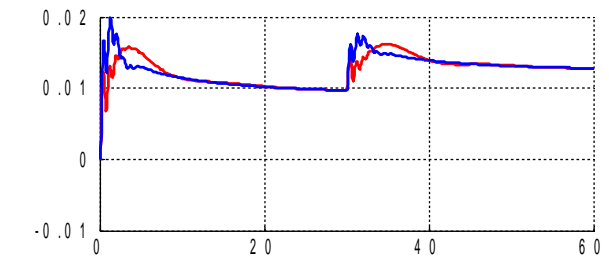

(e)

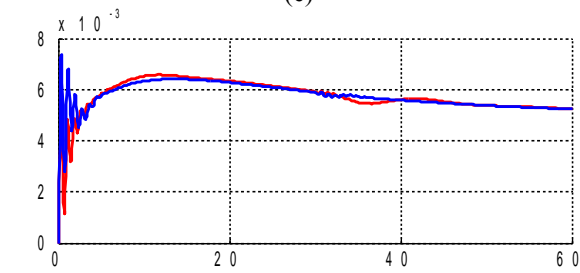

(f)

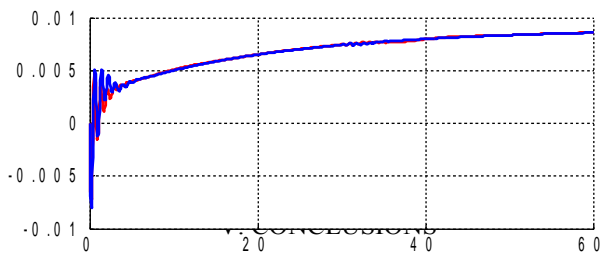

(g)

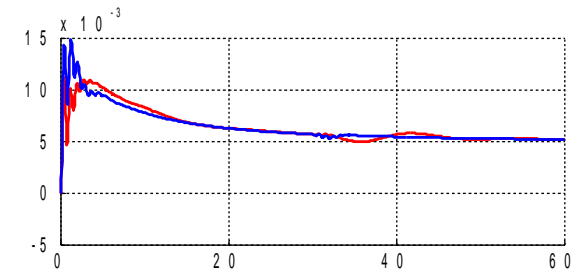

(h)

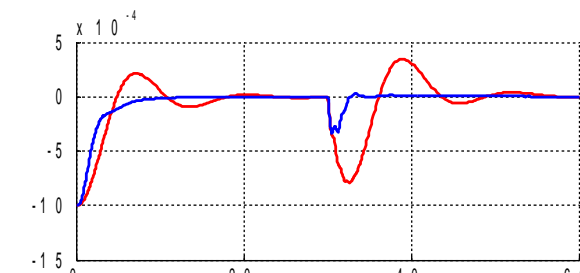

(i)

generator 4, (g) power of generator 5, (h) power of generator 6, (i) tie line power error.

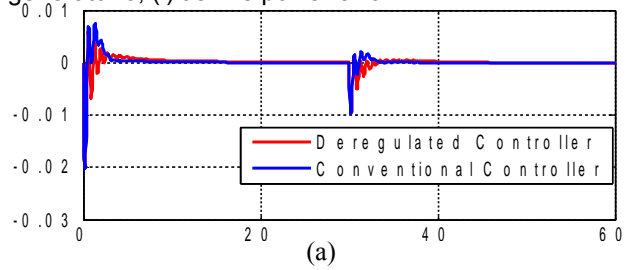

(a)

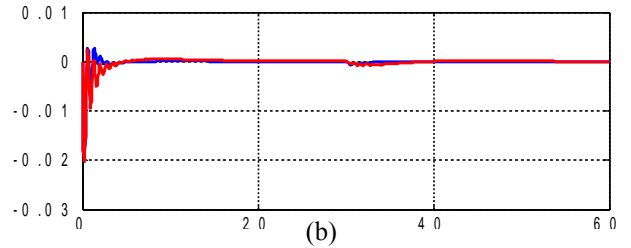

(b)

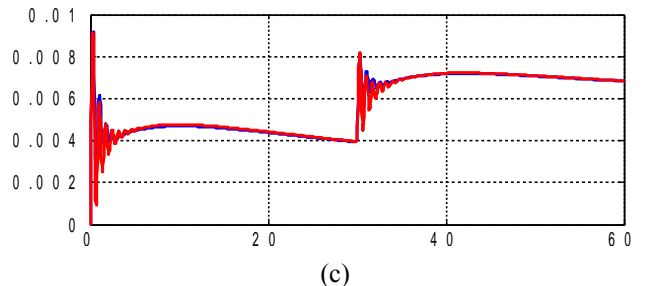

(c)

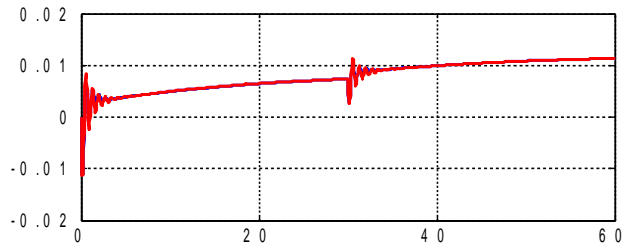

(d)

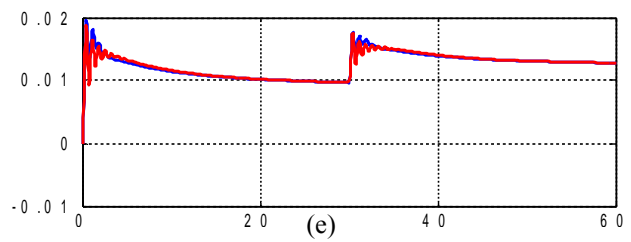

(e)

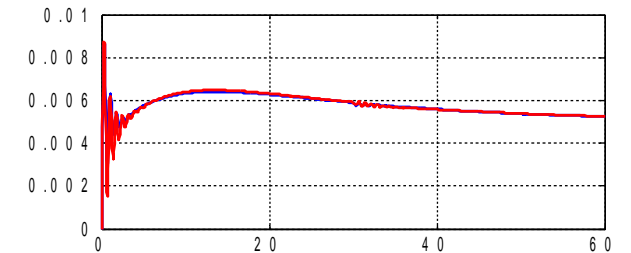

Fig 7. Response of AGC in deregulated power system with HVDC link (a) frequency of area 1,(b) frequency of area 2, (c) power of generator 1, (d) power of generator 2. (e) power of generator 3, (f) power of

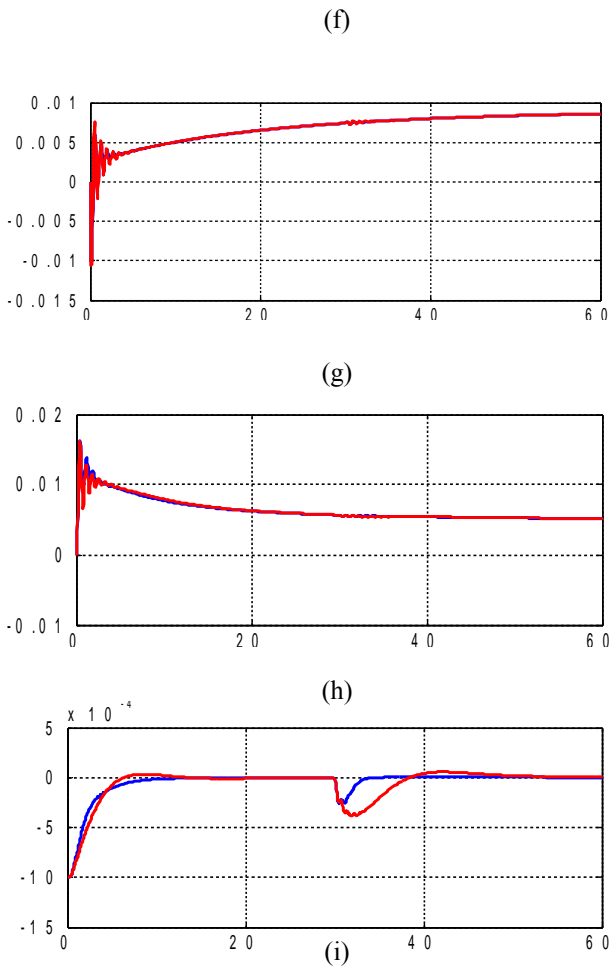

Fig 8. Response of AGC in deregulated power system with SMES (a) frequency of area 1,(b) frequency of area 2, (c) power of generator 1, (d) power of generator 2. (e) power of generator 3, (f) power of generator 4, (g) power of generator 5, (h) power of generator 6, (i) tie line power error.

Results from figure 6 to figure 8 shows the variation in frequency in each control area, response of generators for contracted power and disturbance power and tie line power variation in deregulated power systems with Thyristor Controlled Series Compensation (TCSC), HVDC and AC tie line and Superconducting Magnetic Energy Storage (SMES). To defer the response of the system from contracted load variation to the un contracted load variation a disturbance is created in area 1 with 30sec delay to the load variation. During the contracted load variation each generator is generating power according to their participation mentioned in the DISCO participation matrix. Due to power balance between the generated power by the GENCOs and load demand by the DISCOs, the frequency in each area is settled to its rated value (frequency deviation in the response is settled to zero). The tie line power is

also observed to be at its calculated value is also observed to be at its calculated value from the simulation results. When it comes to the controller response, control parameters designed with conventional AGC are used for deregulated AGC, Figure 6 shows that the performance of the controller is same in the case of deregulated power system with TCSC. Figure 7 and figure 8 shows that control parameters designed with conventional AGC gives better performance with less deviation in frequency, tie line power and less value of settling time in the case of deregulated power system with HVDC link and SMES.

When a load disturbance of 0.01pu is occurred in control area 1 as an un contracted load deviation, figure 6 to figure 8 shows that the disturbance in area 1 causes frequency variation in area 1 to be more than the same area 2. From the response of the generators it is clear that, as a primary action generators in both the areas are responding at the beginning for the disturbance in area 1. But when the secondary control comes in to action, generators in area 1 are only responding for the disturbance in the corresponding area and remaining generators are ineffective in steady state. The tie line power is also unchanged in the steady state because there is no contribution of area 2 generators for the disturbance in area1. When it comes to the controller response, control parameters designed with conventional AGC are used for deregulated AGC, Figure 6 shows that the performance of the controller is same in the case of deregulated power system with TCSC. Figure 7 and figure 8 shows that control parameters designed with conventional AGC gives better performance with less deviation in frequency, tie line power and less value of settling time in the case of deregulated power system with HVDC link and SMES.

VI CONCLUSIONS

Simulation model for automatic generation control in deregulated power systems is presented which includes three types of generating systems(Thermal-Hydro-Gas). Frequency variation due to bilateral contracts and contract violations have been studied with the help of DISCO participation matrix. Dynamic model of Thyristor Controlled Series Compensation (TCSC), HVDC and AC tie line and Superconducting Magnetic Energy Storage (SMES) used in the analysis are presented in the paper. Controller parameters are also selected using PSO algorithm in multi area AGC system with the proposed additional components. Control parameters are designed exclusively for contract violations (disturbance power) in deregulated power systems. Control parameters calculated in the conventional power systems AGC are effectively working even in deregulated power system AGC. So in deregulated power systems, model of AGC is only different but the controller parameters can be used from the conventional power systems. These results are validated with AGC in deregulated power system with

additional components like Thyristor Controlled Series Compensation (TCSC), HVDC and AC tie line and Superconducting Magnetic Energy Storage (SMES).

REFERENCES

- [1] R. Christie and A.bose, Load-frequency control issues in power system operations after deregulation, *IEEE transactions power systems*, Vol.11, pp.1191-1200, Aug. 1996.
- [2] Christie RD, Bose A, Load frequency control issues in power system operations after deregulation, *IEEE Transactions on Power Systems* 1996;11 (3):1191-200.
- [3] Kumar J, Ng Kah Hoe, Sheble G. "AGC Simulator for price based operation part 1: a model", *IEEE Transactions on Power Systems* 1997;12(2):527-32.
- [4] Kumar Jayant, Ng Kah Hoe, Sheble Gerald, " AGC simulator for price-based operation part- I: case study results", *IEEE Transactions on Power Systems* 1997;12(2):533-8.
- [5] Bakken BH, Grand OS. Automatic generation control in a deregulated power system. *IEEE Transactions on Power Systems* 1998;13(4):1401-6.
- [6] Donde V, Pai M A, Hiskens IA. Simulation and optimization in an AGC system after deregulation. *IEEE Transactions on Power Systems* 2001;16(3):481-9.
- [7] Delfino B, Fornari F, Massucco S. Load-frequency control and in advertent interchange evaluation in restructured power systems. *IEE Proceedings- Generation, Transmission and Distribution* 2002; 149(5):607-14.
- [8] Shayeghi Hossein, Shayanfar Heidar Ali. Design of decentralized robust LFC in a competitive electricity environment. *Journal of Electrical Engineering* 2005;56(9-10):225-36.
- [9] Shayeghi Hossein, Shayanfar Heidar Ali, Jalili Aref. Multistage fuzzy PID load frequency controller in a restructured power system. *Journal of Electrical Engineering* 2007;58(2):61-70.
- [10] Shayeghi H. A robust decentralized power system load frequency control. *Journal of Electrical Engineering* 2008; 59(6):281-93.
- [11] Hosseini, Etemadi. Adaptive neuro fuzzy inference system based automatic generation control. *Electric Power Systems Research* 2008; 78:1230-9.
- [12] Abraham RJ, Das D, Patra A. Load following in a bilateral market with local controllers. *Electrical Power and Energy Systems* 2011; 33:1648-57.
- [13] Debbarma S, Saikia LC, Sinha N. AGC of a multi-area thermal system under deregulated environment using non-integer controller. *Electrical Power Systems Research* 2013;95:175-83.
- [14] Bhatt P, Roy R, Ghoshal S. Optimized multi area AGC simulation in restructured power systems. *Electrical Power and Energy Systems* 2010;32: 311-22.
- [15] Tan Wen, Zhang H, Yu M. Decentralized load frequency control in deregulated environments. *Electrical Power and Energy Systems* 2012;41:16-26.
- [16] Bhatt P, Roy R, Ghoshal S. GA/particle swarm intelligence based optimization of two specific varieties of controller devices applied to two-area multi-units automatic generation control. *Int J Electr Power Energy Syst* 2010;32:299-310.
- [17] Joseph R, Das D, Patra A. Damping oscillations in tie-power and area frequencies in a thermal power system with SMES-TCPS combination. *J Electr Syst* 2011;7:71-80.
- [18] Abraham RJ, Das D, Patra A. AGC study of a hydrothermal system with SMES and TCPS. *Eur Trans Electr Power* 2009;19:487-98.
- [19] Rao CS, Nagaraju SS, Raju PS. Automatic generation control of TCPS based hydrothermal system under open market scenario: a fuzzy logic approach. *Int J Electr Power Energy Syst* 2009;31:315-22.
- [20] Bhatt P, Ghoshal S, Roy R. Coordinated control of TCPS and SMES for frequency regulation of interconnected restructured power systems with dynamic participation from DFIG based wind farm. *Renewable Energy* 2012;40:40-50.
- [21] Chidambaram I, Paramasivam B. Genetic algorithm based decentralized controller for load-frequency control of interconnected power systems with RFB considering TCPS in the tie-line. *Int J Electron Eng Res* 2009;1:299-312.
- [22] Bhatt P, Roy R, Ghoshal S. Comparative performance evaluation of SMES-SMES, TCPS-SMES and SSSC-SMES controllers in automatic generation control for a two-area hydro-hydro system. *Int J Electr Power Energy Syst* 2011;33:1585-97.
- [23] Parmar KPS, Majhi S, Kothari DP. LFC of an interconnected power system with thyristor controlled phase shifter in the tie line. *Int J Comput Appl* 2012;41.
- [24] Subbaramaiah K. Comparison of performance of SSSC and TCPS in automatic generation control of hydrothermal system under deregulated scenario. *Int J Electr Comput Eng (IJECE)* 2011;1:21-30.
- [25] Chidambaram I, Paramasivam B. Control performance standards based load frequency controller considering redox flow batteries coordinate with interline power flow controller. *J Power Sources* 2012;219:292-304.
- [26] Chidambaram I, Paramasivam B. Optimized load-frequency simulation in restructured power system with redox flow batteries and interline power flow controller. *Int J Electr Power Energy Syst* 2013;50:9-24.
- [27] Meikandasivam S, Nema RK, Jain SK. Fine power flow control by split TCSC. *Int J Electr Power Energy Syst* 2013;45:519-29.
- [28] Duong T, JianGang Y, Truong V. A new method for secured optimal power flow under normal and network contingencies via optimal location of TCSC. *Int J Electr Power Energy Syst* 2013;52:68-80.
- [29] Padiyar KR. *FACTS controllers in power transmission and distribution*. New Age International; 2007.
- [30] Song YH, Johns AT. *Flexible ac transmission systems (FACTS)*. UK: Institution of Electrical Engineers; 1999.
- [31] Ibraheem, Kumar Prabhat, Kothari DP. Recent philosophies of automatic generation control strategies in power systems. *IEEE Trans Power Syst* 2005;20(1):346-57.
- [32] Kunish HJ, Kramer KG, Domnik H. Battery energy storage – another option for load frequency control and instantaneous reserve. *IEEE Trans Energy Conv* 1986;1(1):46-51.
- [33] Ise T, Mitani Y, Tsuji K. Simultaneous active and reactive power control of superconducting magnetic energy storage to improve power system dynamic performance. *IEEE Trans Power Deliv* 1986;1:143-50.
- [34] Tripathy SC, Balasubramanian R, Chandramohan Nair PS. Effect of superconducting magnetic energy storage on automatic generation control considering governor deadband and boiler dynamics. *IEEE Trans Power Syst* 1992;7(3):1266-73.
- [35] Tripathy SC, Juengst KP. Sampled data automatic generation control with superconducting magnetic energy storage in

power systems. IEEE Trans Energy Conversion 1997;12(2):187–91.

- [36] Aggarwal R P, Bergseth F R. *Large signal dynamics of load-frequency control systems and their optimization using non linear programming: II*. IEEE Transactionson Power Apparatus and Systems 1968;87(2):532–8 PAS-vol..
- [37]Yoshida Y, MachidaT. *Study of the effect of the DC link on frequency control in inter connected AC systems*. IEEE Transactions on Power Apparatus and Systems 1969; 88(7): 1036–42 PAS-vol.
- [38] Bengiamin NN, Chan WC. *3-level load frequency control of power systems inter connected by asynchronous tie lines*. Proceedings of the IEE 1979; 126 (11): 1198–200.
- [39] Ibraheem P, Kumar, Ahmad S. *Dynamic performance enhancement of hydro power systems with asynchronous tie-lines*. IE(I) Journal—EL 2004;85.
- [40] Ibraheem, Kumar P K. *Study of dynamic performance of power systems with asynchronous tie lines considering parameter un certainties*. IE(I) Journal— EL 2004;85:35–42.
- [41] Juang CF, Lu CF. *Load frequency control by hybrid evolutionary fuzzy PI controller*. IEE Proceedings Generation, Transmission and Distribution 2006;153(2):196–204.
- [42] Hosseini, Etemadi. *Adaptive neuro fuzzy inference system based automatic generation control*. Electric Power Systems Research 2008; 78:1230–9.
- [43] Sharifi A, etal.. *Load frequency control in inter connected power system using multi objective PID controller 2008*. In: *IEEE conference on softcomputing in industrial applications*, Muroran, Japan; June2008.p.25–27.
- [44] Sabahi K, etal. *Load frequency control in inter connected power system using multi objective PID controller*. Journal of Applied Sciences 2008;8 (20):3676–82.
- [45] Bhatt P, Roy R, Ghoshal S P. *Optimized multi area AGC simulation in restructured power systems*. Electrical Power and Energy Systems2010;32: 311–22.



K. Hari Krishna received B.Tech. & M.Tech. degrees in Electrical & Electronics Engg. From Jawaharlal Nehru Technological University & Acharya Nagarjuna University in 2003 & 2006 respectively. He is having 11 Years of teaching experience. Currently he is an

Associate Professor in the Department of E.E.E., Kallam HaranadhaReddy Institute of Technology , Guntur. His teaching and research interest include power System Operation and Stability.



Dr. K. Chandra Sekhar received his B.Tech degree in Electrical & Electronics Engineering from V.R.Siddartha Engineering College, Vijayawada, India in 1991 and M.Tech with Electrical Machines & Industrial Drives from Regional Engineering College, Warangal, India in 1994. He Received the PhD, degree from the J.N.T.U, Hyderabad, India in

2008. He is having 21 years of teaching and Research experience. He is currently Professor& Head in the Department of Electrical & Electronics Engineering, R.V.R & J.C. College of Engineering Guntur, India. His Research interests are in the areas of Power Electronics, Industrial Drives & FACTS Controllers.