

GREY WOLF OPTIMIZATION BASED PI CONTROLLER TO MAINTAIN CONSTANT DC LINK VOLTAGE FOR IMPROVING THE PERFORMANCE OF SHUNT ACTIVE FILTER

R.Karthika¹, V.Suresh Kumar², T.Eswaran³

¹Assistant Professor

Department of Electrical and Electronics Engineering
Theni Kammavar Sangam College of Technology, Theni-625534 India

²Associate Professor, ³Research Scholar

Department of Electrical and Electronics Engineering
Thiagarajar College of Engineering- Madurai-625 015 India

Email: eksee@gmail.com, vskee@tce.edu, eswaranthangaraju@tce.edu

Abstract: *This paper introduces new algorithm to improve the performance of a Shunt Active Filter (SAF) by tuning the PI controller gain in order to maintain constant dc link voltage for non-linear balanced and unbalanced loads. The planned PI controller utilize a new artificial intelligent technique methods called grey wolf Optimization (GWO) for tuning the gain parameters of PI controller to attain optimality for SAF dc link voltage. For testing the heftiness of the controller unbalanced resistive loads that fed from uncontrolled three-phase bridge rectifier, proposed system uses balanced are taken as a non-linear loads. the hysteresis current control method and the instantaneous PQ theory is used to make the reference current is used in this strategy to distinguish the the actual currents and extracting reference in order to make the switching pulse for the Shunt Active Power Filter method. Determined Simulation results are attain with (Matlab/Simulink) it demonstrates so as to the GWO based PI controller tuning method is effective for maintaining the constant dc link voltage in minimum time period to improve the performance of the active filter.*

Key words: *Shunt Active Filter, PI controller, DC link voltage, Grey Wolf Optimization*

1. Introduction

In the recent past years there has been an increase of non linear loads in the electric power distribution networks [1]. The power quality of the electric power distribution network is extremely affected predominantly by harmonics due to increased use of non linear loads like as; dc drives solid state ac and power electronic convertors, arc and induction furnace etc [2]. Such harmonics not only make more current stress and voltage but also accountable for harmonic resonance, electromagnetic interference, capacitor failure etc [3] [4].

Subsequently, current harmonics and has the voltage increase into a grave problem in distribution systems and transmission. Passive filters contain

conventionally used to eradicate the harmonics in utilities because of less price but it cannot provide a complete solution. Therefore, active filters are introduced to mitigate harmonic distortion [5]. Active power filters are divided into hybrid, series and shunt [6,7]. The shunt active filter (SAF) is most common among other types. The SAF is a current controlled voltage source inverter attached in parallel with the loads which supplies the compensating current to improve the power quality [8]. The SAF can eliminates both harmonics and correct the power factor. In addition to this, SAF can also be used to balance the supply current by supplying the required amount of active power per phase to the load [15]. The SAF has lot of advantages of lesser size as compared to passive filters altering and compensation characteristics. Eventually, this would make sure a pollution free system with amplified quality and reliability.

Shunt active filter is a very complex nonlinear dynamic compensation system. It must effectively compensate for the harmonic current system, in accordance with the laws of pulse-width modulation (PWM) control, capacitor voltage of DC side in main circuit must remain constant, thus providing a voltage reference, so controlling DC side voltage of the active power filter is very pivotal [9]. Usually we adopt the traditional PI control strategy to control DC side voltage of APF to keep it in an appropriate value, but the traditional PI control technology relies on the mathematical model, poor robustness, the inappropriate choice in proportional parameters and integral parameters of the PI control strategy is easy to bring overshoot voltage and impulse current, which causes a serious impact on the entire system [10]. The dc-link voltage is controlled by tuning the PI controller which reduces the harmonics level [11]. In many strategies for the APF design

using an Artificial Intelligence (AI) technique like as ABC algorithm, particle genetic algorithm (GA), swarm optimization (PSO). Grey wolf optimization algorithm is a swarm intelligent technique widened by [12], where mimics the wolves' leadership hierarchy is well known for their, well developed social behaviour, leadership quality and group hunting.

Grey Wolf Optimization algorithm (GWO) is commenced for tuning the increase of the controllers. Regulating optimized controller regulates the dc link voltage as per the signal harmonics and consequently the active power loss of the system is minimized. Therefore, the precise compensation current should be injected by the devices SAF. The planned controller based harmonic compensation method is implemented in (MATLAB/Simulink) platforms. The solutions of traditional PI, Grey Wolf Optimization based PI controllers, and Bee colony algorithm based PI are investigated. The fast DC-link voltage response is attained through the proposed optimization algorithm.

2. Shunt active filter

A SAF is connected to a harmonic polluted power system of common coupling point between the harmonic producing load and voltage supply. The configuration of a SAF has two main elements explicitly, a controller and a standard voltage source inverter. The overall circuit formation of a typical voltage source inverter based SAF is shown in Figure 1. Its controller comprises three main sections, switching pulse generation reference current generation, voltage regulation and dc-link capacitor.

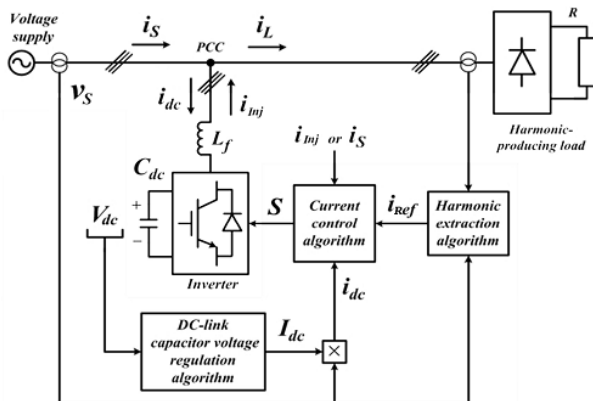

Figure 1 Structure of parallel active filter

The current flow in the nonlinear system without SAF compensation is mathematically expressed as:

$$i_s = i_L = i_F + i_H \quad (1)$$

" i_F " Is the essential current and " i_H " is the harmonic current produced by the nonlinear loads. In this scenario, the source current " i_s " is warped and displaced away from the source voltage V_s due to addition of i_H . Two additional currents flow in the harmonic polluted power system since the connection of the SAF at the PCC: they are, (i) injection current " i_{inj} " which is injected by the SAF to stop out " i_{Har} " in the system and dc-link charging current " i_{dc} " which is a little amount of current drawn by the SAF for regulating its switching losses and to preserve V_{dc} as steady level state. The supply current in nonlinear system with SAF is written as,

$$i_s = (i_F + i_H) - i_{inj} \quad (2)$$

The SAF effectively recover the sinusoidal shape of supply current i_s . So that the supply current regains its sinusoidal characteristic and work in-phase with V_s .

Therefore the equation (1) becomes

$$i_s = i_F \quad (3)$$

3. Dc Link capacitor voltage regulation with PI controller

Commonly, dc-link capacitor voltage regulation is belongs to a voltage source inverter depends SAF formation where a dc capacitor is usually installed for energy storage system. However, the viability of this situation is a question in practical scenarios. The voltage remaining constant is vital in an ideal case with no real power exchange between the AC network and the SAF. In this consequence of power losses in the power converter which runs from the switching activities and conduction. It leads to the crucial feature of the dc link capacitor voltage regulation in the preservation of a constant voltage transversely the dc link capacitors. The ensuing error is used for the assessment of the suitable magnitude " I_{dc} " of the instantaneous dc link charging current " i_{dc} ". The organize algorithm takes the instantaneous dc link capacitor voltage " V_{dc} " and makes a comparison thereof with a desired reference value. The estimated " I_{dc} " is the amount of " i_{dc} " required to be drawn by the SAF for the purpose of modifiable its switching losses to make easy constant upholding of dc link capacitor voltage " V_{dc} " at the needed reference cost.

Fundamentally regulation of the dc link capacitor voltage is carried out through control of the real power strained by the SAF throughout its operation

of switching. The achievement of the voltage regulation process becomes a reality when the actual power strained by the SAF is got on part with its losses of switching. Consequently, a constant maintenance of the appropriate function of SAFs needs a appropriate adjustment of the magnitude of the reference present "i_{Ref}" through direction of the magnitude "I_{dc}" of a control variable recognized as the instantaneous dc link charging current by SAF for facilitating compensating its switching losses revealed in Figure 2.

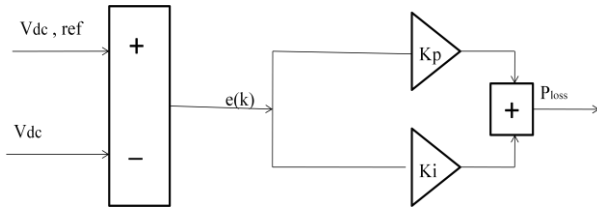

Figure 2 Traditional PI controller

The regulation equation is expressed as follows,

$$\overline{P_{loss}} = K_p \Delta V_{dc} + K_i \int_0^t \Delta V_{dc} dt \quad (4)$$

where, $\overline{P_{loss}}$ is the average active power loss occurring in active filter inverter that is obtained from dc-link voltage regulator. In the above mentioned equations, the actual dc link voltage V_{dc} is varied with a reference V_{dc}^* and the error ΔV_{dc} is custom in PI controller. Actual performance of the dc link regulator is based on the K_p and K_i increase of the PI controller. In this work, the gain of the PI controller is tuned by grey wolf optimization algorithm. The increase of PI controller K_p and K_i is optimized by Grey Wolf Optimization algorithm and the standard active power loss $\overline{P_{loss}}$ is reduced. The intention equation model is chosen as the equation (4). From the best gain K_p and K_i , the controller is fine tuned and the $\overline{P_{loss}}$ is reduced. Afterwards, the reference current values are determined by comparing the source current to the reference current. Following that, control pulse is executed and the VSI operation is embarrassed.

4. Grey wolf optimization algorithm

Grey wolves are measured as apex predators in this algorithm. At the top of the food chain in chasing and mostly preferred to live in a pack of group. In group size is on average of 5–12. The ‘ α ’ wolf is mainly accountable for taking assessments like time to wake, sleeping place, hunting, and other choices. The leaders a male and female, called ‘ α ’ wolves. ‘ α ’ leader “wolf decisions” are regimented to the pack of groups. However, some kind of democratic behaviour has also been observed, in which an alpha follows the other wolves in the pack. [13].

Subsequently in the hierarchy of grey wolves is called as ‘ β ’ wolves. The beta wolf can be moreover a male or a female, and she / he is most likely the best applicant to be the alpha in the case one of the alpha wolves passing left or flatter very old. The betas are subordinate wolves that assist the alphas in other pack activities or decision-making. The ‘ β ’ wolf should follow the ‘ α ’ values. Although, orders provided to the other lower level wolves.

In case, wolf is not a ‘ α ’, ‘ β ’, or ‘ ω ’, she / he is called a subordinate. Delta wolves have to give in themselves to betas and alphas, other than they control the omega. Caretakers Elders, sentinels, scouts, and hunters depends on this groups. Wolf of scouts is accountable for surveillance the boundaries of the territory and caution the pack in case of any risk and complexity.

‘ ω ’ wolves are to surrender themselves to all the other main leader wolves, the last wolves that are allowed to consume. The least ranking grey wolf is ‘ ω ’. Even as acting the function of a scapegoat. ‘ ω ’ wolf is not an vital individual in the group pack.

In accumulation to the social hierarchy of wolves, group hunting is a different interesting social grey wolf’s performance. The main phases of grey wolf are attacking the prey, hunting and hunting-encircling according to [14].

The algorithmic steps involved in GWO areas are as follows.

- Attack towards the victim
- Tracking, distressing, and encircling the prey until it stops stirring.
- Tracking, approaching, and chasing the victim.

5. GWO algorithm based PI controller gain optimization

Parameters of traditional PI controller are obtained by Ziegler-Nichols method tuning, the proportional gain and integral time length is obtained through a lot of experiments and experience. In this paper, in order to improve the dynamic performance of the system, using grey wolf optimization algorithm to adjust the parameters of PI controller, thus minimize the p_{loss} . The control principle diagram using GWO algorithm based PI control parameters optimization is shown in Figure 3.

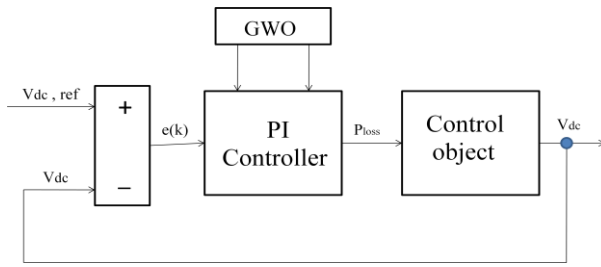

Figure 3 GWO based control schematic diagram of PI

The optimum solution is suggested as the alpha for modelling the social hierarchy of wolves until and unless designing GWO. Seeing as, the second and third best results are mentioned by delta (δ) and beta (β) correspondingly. The (x) wolves pursue of these three wolves. The rest of the candidate results are mentioned as omega (ω). The step and procedure for encircling performance is model leads mentioned below:

Step1: Initialize the GWO parameters such as design variable Size (Gd), vectors a , A , C , search agents (X_i) and maximum number of iterations (itermax). Following that encircling Behaviour is modelled as mentioned below equations.

$$\vec{D} = |\vec{C} \cdot \vec{X}_p(t) - \vec{X}(t)| \quad (6.1)$$

$$\vec{X}(t+1) = \vec{X}_p(t) - \vec{A} \cdot \vec{D} \quad (6.2)$$

Anywhere “ t ” is the current iterations, \vec{A} and \vec{C} is coefficient vectors, $\vec{X}_p(t)$ mentions the victim position vector. The vectors \vec{A} and \vec{C} can be measured as mentioned below equations:

$$\vec{A} = 2\vec{a} \cdot \vec{r}_1 - \vec{a} \quad (6.3)$$

$$\vec{C} = 2 \cdot \vec{r}_2 \quad (6.4)$$

Where \vec{a} encloses linearly decreased from 2 to 0 value more than the course of iterations and \vec{r}_1 and \vec{r}_2 are random vectors in the [0, 1] range.

Step 2: Make wolves randomly depends on boundary conditions methods can be equated as,

$$U = \text{rand}(1, X_i) \quad (6.5)$$

$$L = \text{rand}(1, X_i) \times 0.2 \quad (6.6)$$

Step 3: Calculate the fitness value of every hunt agent using the below mentioned equations.

$$F(t) = \begin{cases} \frac{1}{1 + \overline{p_{loss}}(t)} & \text{if } \overline{p_{loss}}(t) \geq 0 \\ 1 + \text{abs}\left(\overline{p_{loss}}(t)\right) & \text{if } \overline{p_{loss}}(t) < 0 \end{cases} \quad (6.7)$$

The first implementations of GWO algorithm, three of well defined solutions will be calculated so far subsequent compel the other search agents (including the omegas) and the speedy implementation to appraise their positions due to the most excellent search mediators. For this step, Mathematical model as shown in below mentioned equations:

Step 4: Determine the first to third best hunt agent such as (X_α), (X_β) (X_δ) using equations (6.8)-(6.13).

$$\vec{D}_\alpha = |\vec{C}_1 \cdot \vec{X}_\alpha - \vec{X}| \quad (6.8)$$

$$\vec{D}_\beta = |\vec{C}_2 \cdot \vec{X}_\beta - \vec{X}| \quad (6.9)$$

$$\vec{D}_\delta = |\vec{C}_3 \cdot \vec{X}_\delta - \vec{X}| \quad (6.10)$$

$$\vec{X}_1 = \vec{X}_\alpha - \vec{A}_1 \cdot (\vec{D}_\alpha) \quad (6.11)$$

$$\vec{X}_2 = \vec{X}_\beta - \vec{A}_2 \cdot (\vec{D}_\beta) \quad (6.12)$$

$$\vec{X}_3 = \vec{X}_\delta - \vec{A}_3 \cdot (\vec{D}_\delta) \quad (6.13)$$

Step 5: Renovate the location of the current hunt agent by means of equation mentioned (6.14)

$$\vec{X}(t+1) = \frac{\vec{X}_1 + \vec{X}_2 + \vec{X}_3}{3} \quad (6.14)$$

Step 6: Assess the fitness value of all the calculated hunts.

$$p(t) = \frac{Fit(t)}{\sum_{t=1}^{CS/2} Fit(t)} \quad (6.15)$$

Step7: Implement the values of X_α , X_β and X_δ .

Step 8: Verify for stopping condition, whether the iterations reaches $iter_{max}$, if yes means, print the

optimum value of solution otherwise depart to step number 5.

In otherwise, a α , β , and δ approximate the victim position whilst the other wolves bring up to date their positions randomly about the victim. The final position could be in a random state with in a circle which is illustrated by the positions of α , β , and δ in the search space method. Grey wolf optimization algorithm flowchart is publicized in Figure 5.

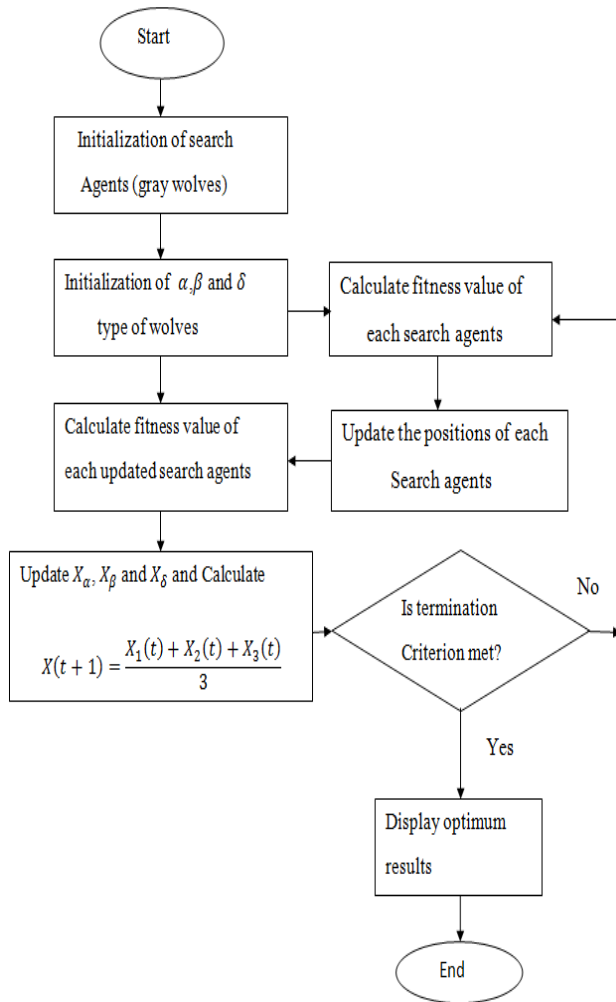

Figure 5 Flowchart of GWO algorithms

6. Simulation effects and its discussion

SAF control model is implemented and executed in (MATLAB/Simulink) working podium in order to verify the control effect of the grey wolf optimization PI controller parameters in DC link voltage regulation. It was followed by confirmation of the

effectiveness of proposed control approach and implementation parameters are shown in Table1. The performance of proposed controller is evaluated by the following two cases nonlinear balanced load and unbalanced load.

A three phase voltage source, and an uncontrolled rectifier with balanced and unbalanced resistive loads attached through circuit breakers are the system components. The time required for stabilization of the system reaches for various control algorithms (IABC) Improved Artificial Bee Colony, (GWO) Grey wolf optimization algorithm, (ABC) Artificial Bee Colony Algorithm are compared in Table 2. The lively filter with proposed control approach is connecting to the system at the point of common coupling system.

Table 1
Implementation Parameters

Parameters	Values
Load 1	Non-Linear balanced Load 5 kohm
Load 2	Non-Linear Unbalanced Load 1 kohm, 2.5 kohm, 3.7 kohm

Table 2
Ccomparisons results of various algorithms

Controllers	Settling Time in sec	
	Nonlinear Balanced Load	Nonlinear Unbalanced Load
PI	0.44	0.45
ABC-PI	0.34	0.35
IABC-PI	0.30	0.31
GWO-PI	0.23	0.24

The simulation result shows that the grey wolf optimization based PI controller has reach the steady in a shorter period of time than the other control methods. This means that optimization of the GWO improves the flexibility of the controller; the system has better dynamic performance, and gets a good control effect. The estimated simulation results of the dc link voltage waveform for various controllers are shown in Figure 6 and Figure 7. As seen from the dc link voltage waveforms shown in Figure 6, the grey wolf optimization based PI controller maintain the dc link voltage as constant in minimum period for the two balanced load conditions.

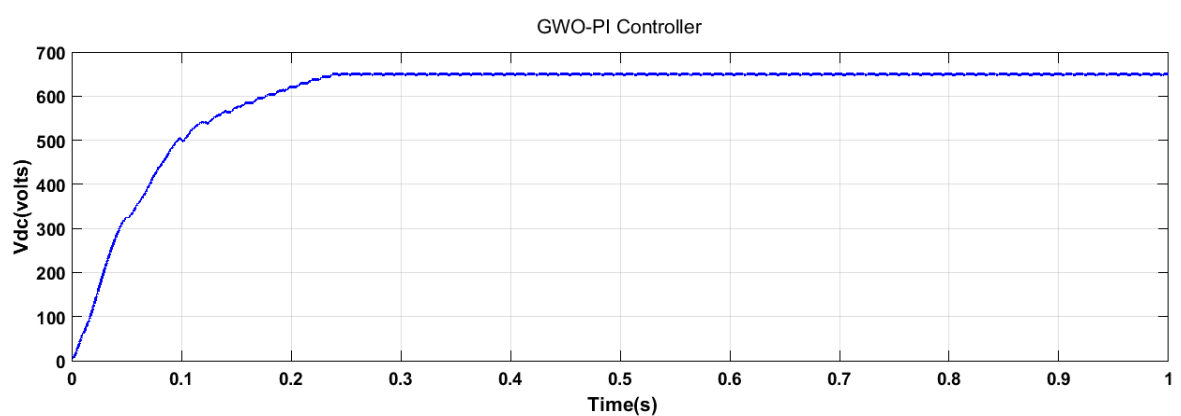
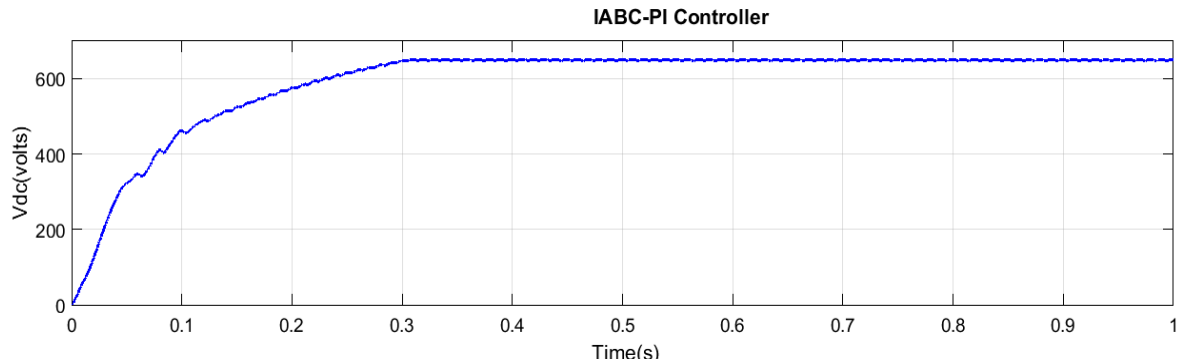
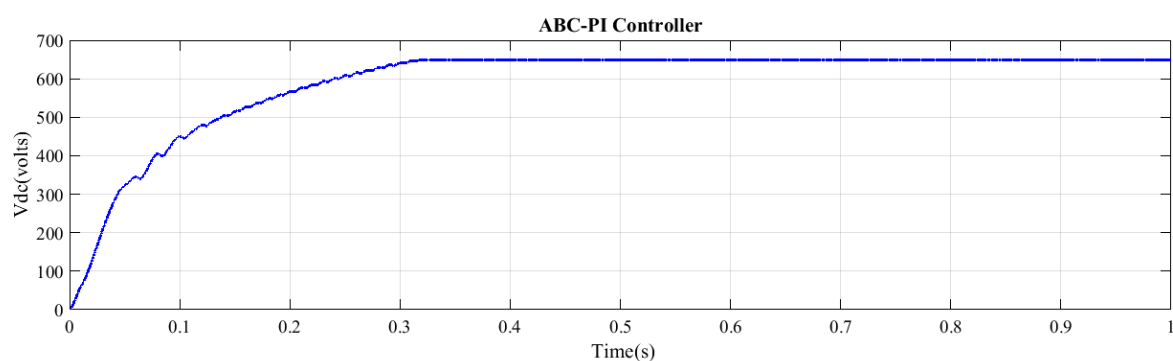
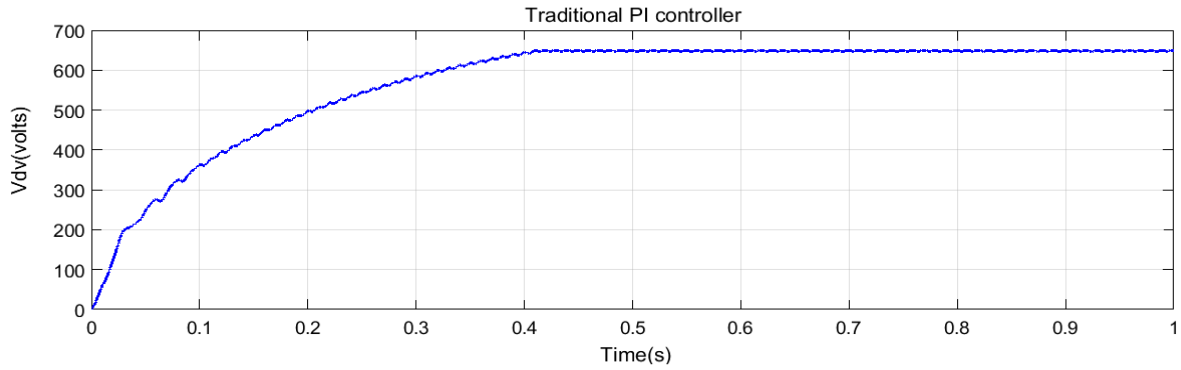

Figure 6 DC link voltage for nonlinear balanced load

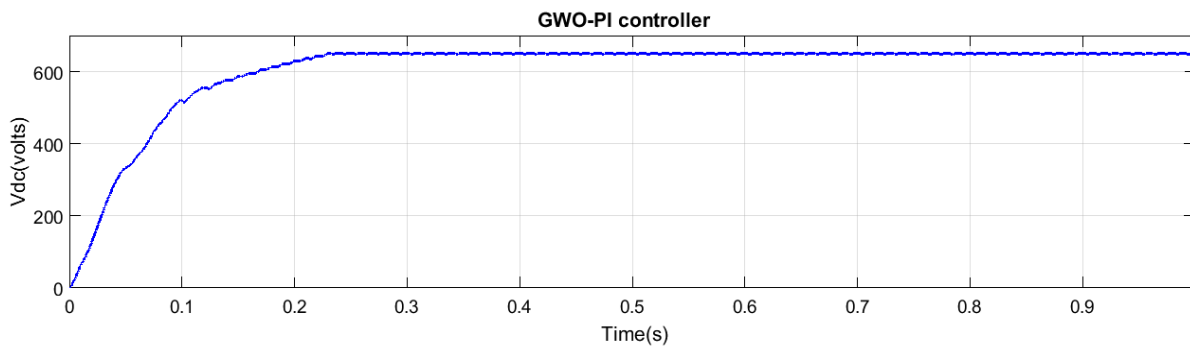
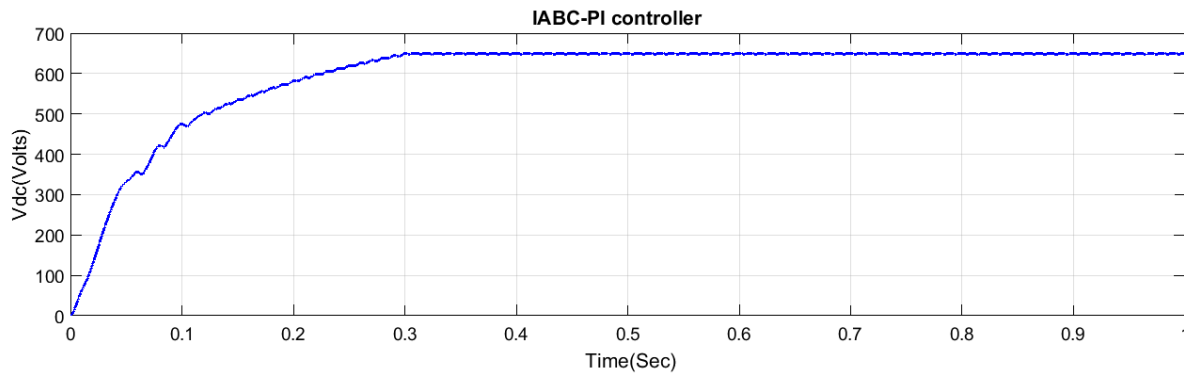
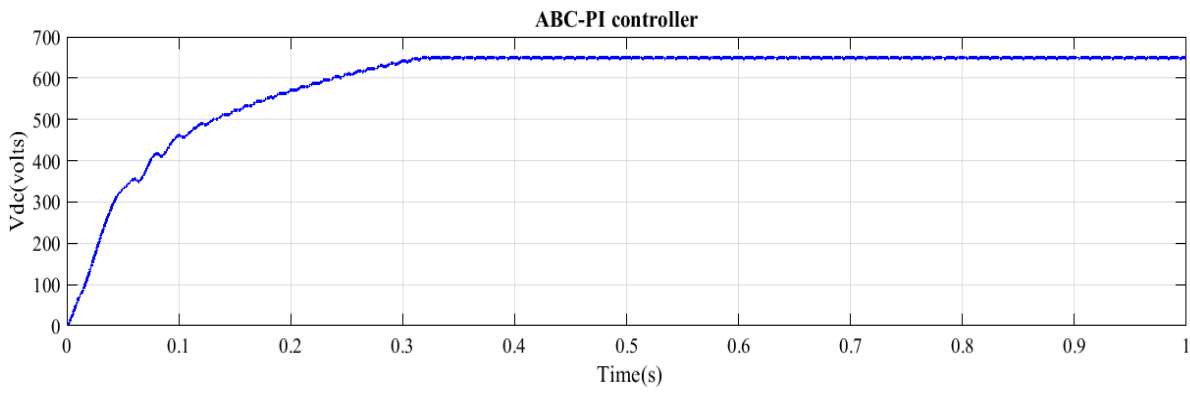
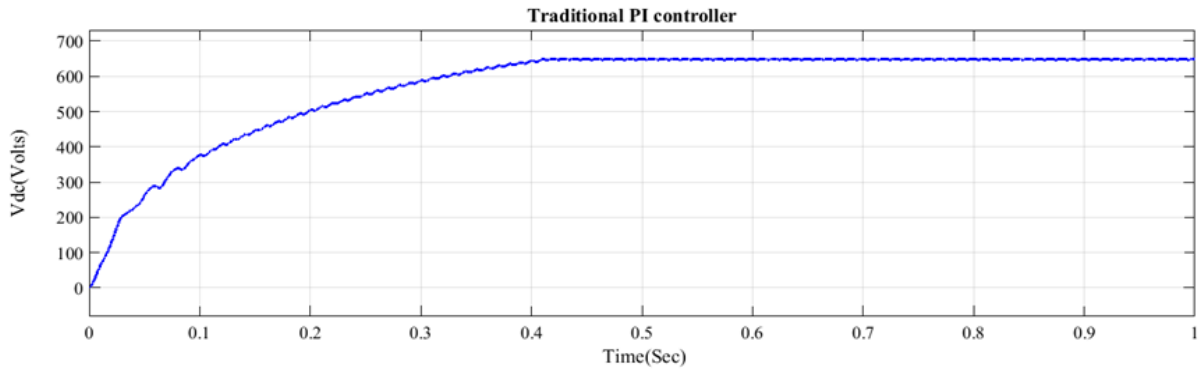

Figure 7 DC link voltage for nonlinear unbalanced load

Also, the transient response of GWO algorithm based PI controller is better than other controllers. Similarly, the merits of GWO algorithm based PI controller seen in Figure 7 for unbalanced load conditions.

7. Conclusions

In this article, the dc- Link voltage of the shunt active filter is maintained constant using PI controller. An intelligent technique called grey wolf optimization is concluded for optimization of PI gain parameters and fine tuning. The heftiness of the controller is delaminated by pertain two scenarios of loads nonlinear balanced and unbalanced. From simulation results, show that, the method proposed in this paper in maintaining the DC link voltage as constant of active power filter is feasible and effective, and by optimizing the parameters of PI controller to ensure that the active power loss is minimized and the time required for settling the dc link voltage is also minimized to improving the dynamic performance of the entire system.

References

- [1] Sincy George and Vivek Agarwal, A DSP based optimal algorithm for shunt active filter under non sinusoidal supply and unbalanced load conditions, *IEEE Transactions on Power Electronics*, 2007, vol. 22, no. 2, PP.593-601.
- [2] Wu Longhui, Zhuo Fang, Zhang Pengbo, Li Hongyu, and Wang Zhaoan, 'Study on the Influence of Supply-Voltage Fluctuation on Shunt Active Power Filter', *IEEE Transactions on Power Delivery*, 2007, VOL. 22, NO. 3, PP. 1743-1749
- [3] Z. Liu, B. Liu, S. Duan, and Y. Kang, A novel DC capacitor voltage balance control method for cascade multilevel STATCOM, *IEEE Transactions on Power Electronics*, 2012, vol. 27, no. 1, pp. 14-27.
- [4] R. L. A. Ribeiro, T. O. A. Rocha, R. M. Sousa, E. C. dos Santos, A. M. N. Lima, 'A Robust DC-Link Voltage Control Strategy to Enhance the Performance of Shunt Active Power Filters without Harmonic Detection Schemes', *IEEE Transactions on Industrial Electronics*, 2015, Vol.62(2), PP.803-813.
- [5] Priyabrat Garanayak and Gayadhar Panda, Harmonic Elimination and Reactive Power Compensation with a Novel Control Algorithm based Active Power Filter, *Journal of Power Electronics*, 2015, vol.15(6), pp.1619-1927.
- [6] Hurel J, Mandow A, Garcia Cerezo A Tuning a fuzzy controller by particle swarm optimization for an active suspension system, paper presented at: *IECON 2012-38th Annual Conference on IEEE Industrial Electronics Society*; 2012, pp. 25-28.
- [7] Patnaik, SS, Panda, AK, Performance Improvement of id-iq Method Based Active Filter Using Particle Swarm Optimization, *International conference on Sustainable Energy and Intelligent Systems*, 2011, pp. 320-325.
- [8] B-R.Lin,T-Y.Yang, 'Three level voltage source inverter for shunt active filter', *IEEE Proceedings-Electric Power Applications*, 2004, Vol.151, pp.744-751.
- [9] Yap Hoon, Mohd Amran Mohd Radzi, Mohd Khair Hassan and Nashiren Farzilah Mailah, *Control Algorithms Of Shunt Active Filter For Harmonics Mitigation: A Review*, *Energies*, 2017, vol.10, pp.1-29.
- [10] Corasaniti, VF, Barbieri, MB, Arnera, P, Valla LM, Hybrid Active Filter for Reactive and Harmonics Compensation in a Distribution Network, *IEEE Trans. on Industrial Electronics*, 2009, vol. 56, no. 3, pp. 670-677.
- [11] He Dongchen, Wu Linzhang, Wu Tiezhou and Jiang Xiaowei, Optimization of PI control parameters for shunt active power filter based on PSO, *Advanced Materials Research*, 2015, vols. 1070-1072, pp. 1268-1277.
- [12] Seyedali Mirjalili, Seyed Mohammad Mirjalili and Andrew Lewis, Greywolf optimizer, *Advances in Engineering Software*, 2014, vol. 69, pp. 46-61.
- [13] David Mech. L, Alpha status, dominance, and division of labor in wolf packs, *Can J Zool*, 1999, vol.77, pp.1196-1203.
- [14] Muro C, Escobedo R, Spector L, Coppinger R, Wolf-pack hunting strategies emerge from simple rules in computational simulations, *Behavioural Processes*, 2011, vol.88, pp.192-197.
- [15] Shahidinejad S, Filizadeh S, and Bibeau E, Profile of charging load on the grid due to plug-in vehicles', *IEEE Trans. on Smart Grid*, 2012, vol. 3, no. 1, pp. 135-141.