

SPWM CONTROLLED EMBEDDED Z-SOURCE INVERTER FED THREE PHASE INDUCTION MOTOR DRIVE WITH REDUCED THD

R.MALATHI

Department of Electrical and Electronics Engineering,
SCSVMV University, Kanchipuram, India
malathinandhini@yahoo.co.in

M.RATHINAKUMAR

Department of Electrical and Electronics Engineering
SCSVMV University, Kanchipuram, India
rathinamari@rediffmail.com

Abstract: This paper presents the simulation and hardware implementation of Sinusoidal pulse width modulated Embedded Z-Source inverter fed three phase induction motor drive. Voltage Source Inverter (VSI) and Current Source Inverter (CSI) are the two conventional converters used with induction motor drives in industrial applications. Conventional VSI and CSI can perform either buck or boost operation from DC-AC power conversion. The Z-Source inverter overcomes the problems associated with VSI or CSI. Z-Source Inverter employs a unique LC impedance network to match the inverter main circuit to DC voltage source. The conventional converters have eight switching states, six active states and two non shoot through zero states. One more switching state, shoot through zero state is possible with ZSI due to presence of LC impedance network. By controlling the shoot through duty cycle any desired DC output voltage can be obtained. Zero state voltage buck-boost capability. EZSI has been developed from ZSI concepts, with voltage source embedded within the impedance network, produces same voltage gain as that of ZSI and maintains smooth voltage or current across the impedance network. This can be achieved without any additional passive filter. The EZSI provides voltage ride-through capability, reduced harmonics and increased output voltage. This paper proposes sinusoidal pulse width modulated EZSI for three phase induction motor drive.

Key words: Z-Source Inverter (ZSI), Embedded Z-Source Inverter fed Induction Motor (EZSIIM), Sinusoidal Pulse Width Modulation (SPWM), Shoot-through.

1. Introduction

The traditional Induction motor drive system is based on voltage source inverter (VSI), VSI fed induction motor drives have the following limitations and problems:

The output voltage of VSI is less than the DC link voltage, VSI is a buck inverter. The low obtainable voltage significantly limits the output power; this is an undesirable situation for many drive applications. Voltage sags can interrupt the drive system and may result in shutting down of critical loads and processes. 90% of power quality problems are based on momentary voltage sags. The upper and lower switches of same phase leg cannot be gated on simultaneously, that results in shoot through which destroy the drives this affect the converter reliability. An output LC filter is required to

provide a sinusoidal voltage to provide single stage power conversion. Both the VSI and CSI have the following problems:

They are either a boost or a buck converter and cannot be a buck boost converter. Their main circuits cannot be interchanged They are vulnerable to EMI noise in terms of reliability. The above mentioned problems are overcome by the Z-Source inverter first proposed in [1], various topologies of ZSI have been developed and analyzed with Voltage type or current type conversion [1], [2]. Among them V-type ZSIs are more popular and tested for adjustable speed drives [3], fuel cell [1], [6] and PV powered systems [4], [5]. Many pulse width modulation schemes [7] - [10] have been developed to control Z-Source inverter for lower switching loss and others realizing optimized harmonics. Conventional modulation techniques can be modified by properly inserting shoot-through States to switch the ZSI continuously or discontinuously and retaining the unique harmonic performance features of the conventional modulation strategies is presented in [7], two constant boost control methods for ZSI is presented in [8], to obtain maximum voltage gain at any given modulation index without producing low frequency ripple and reduces the voltage stress. The maximum boost control method is presented in [9], Space vector modulation techniques for ZSI/qZSI are discussed in [10]. Generalized PWM algorithm for VSI fed ac drives is presented in [11]. The input Diode is subjected to high frequency operation during voltage boost operation, resulting in chopping current flowing to the DC source, which might degrade the source characteristics? The chopping current can be filtered by placing a second order LC filter before Diode. But addition of filter raise the overall cost of the system and might introduce unnecessary dynamics and resonant complications to the system if it is not designed properly. Instead of using external filter [12] proposes Embedded Z-Source inverter (EZSI) which adopts the concept of embedding the input DC source within the LC impedance network. The existing inductive elements are used for current

filtering in voltage type EZ-Source inverter, capacitive elements for voltage filtering in current type EZSI. The voltage or current gain of the EZSI is kept unchanged despite of this modification. EZ-source inverters are broadly classified into shunt or parallel embedded Z-source inverter and presented in [13]. Asymmetric and symmetric type of EZSI are discussed in [14], EZSI with ripple input current and continuous input current are proposed in [15] which provides high boost voltage inversion ability, lower voltage stress across the active switches, a continuous input current and reduced voltage stress across the capacitors. Embedded controlled Four switch three phase Z-source inverter is proposed in [16] reduces the number of switches and control circuit complexity. Study state performance of VSI fed induction motor drive for different frequency is discussed in [17]. The above literature does not deal with comparison of simulation & hardware results of EZSI fed induction motor drive system.

This paper proposes sinusoidal pulse width modulated EZSI for three phase induction motor drive. SPWM EZSI fed three phase induction motor is designed, modeled and simulated using Matlab/Simulink. The prototype of EZSI fed three phase induction motor is designed and experimental results are verified.

The organization of the paper is as follows:

Literature survey on EZSI is presented in section I. ZSI is introduced in second section II. Analysis of EZ network is presented in section III. SPWM control is discussed in section IV. Simulation and experimental results are given in section V & VI. The work is concluded in section VII

2. Z Source Inverter (ZSI)

The Z-Source network shown in Fig.1. Employs a unique LC impedance circuit, which couples the main circuit to the power source, load, or another converter.

Fig .1. Z-Source Inverter

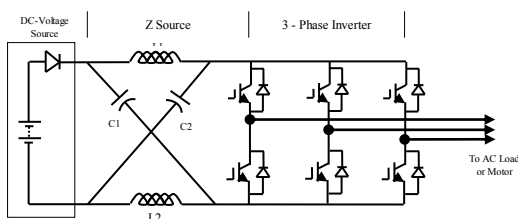

This Z-Source converter provides unique features that cannot be obtained with V-Source and I-source converter. The LC impedance network consists of a split

inductor L1 and L2, and capacitors C1 and C2 connected in X- Shape which allows the short circuiting of DC link of the inverter, resulting in shoot through zero state, provides voltage boosting compatibility for the inverter without damaging the switching devices. During this shoot through zero state energy is transferred from capacitor to the inductor. Diode is required to prevent the discharge of overcharged capacitor through the source. Thus Z-source network makes the shoot through zero state possible. This shoot through zero state provides the unique buck boost feature to the inverter.

The block diagram of existing IMD system is shown in Fig .2. The block diagram of proposed system is shown in Fig .3. VSI is replaced by ZSI.

Fig .2. Existing IMD system

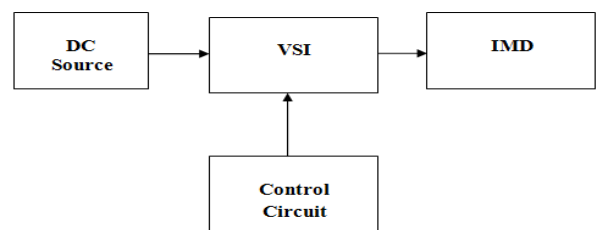
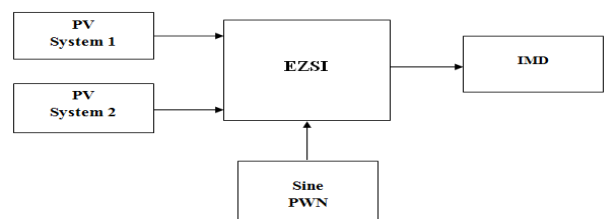

Fig .3. Block diagram of proposed EZSI fed IMD System



3. EZ Source Network

Based on the concept of Z-Source inverters Embedded Z-Source inverters are developed by inserting DC source into the X-shaped impedance network, so that the DC input current flows smoothly during the whole switching period unlike the traditional Z-Source inverter. EZ-Source two level voltage type inverter is shown in Fig.4 . This EZSI can produce the same gain as that of ZSI but with smoother and smaller current/voltage maintained across the DC input source and within the impedance network. These features are obtained without using any additional passive filter.

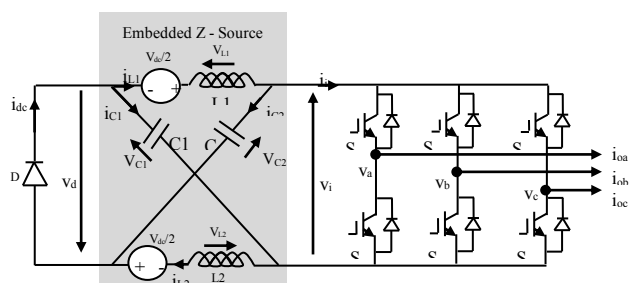

Fig. 4. Two level Three-phase Embedded Z-Source Inverter

During the shoot through zero state of the EZSI the front end diode D is reverse biased with its blocking voltage as shown in Fig.5.

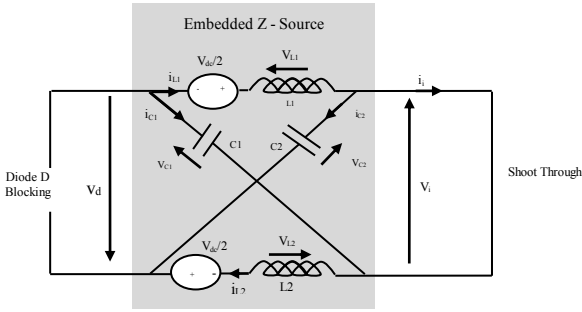

Fig.5. Equivalent circuit of two-level EZ-source inverter when in shoot-through state.

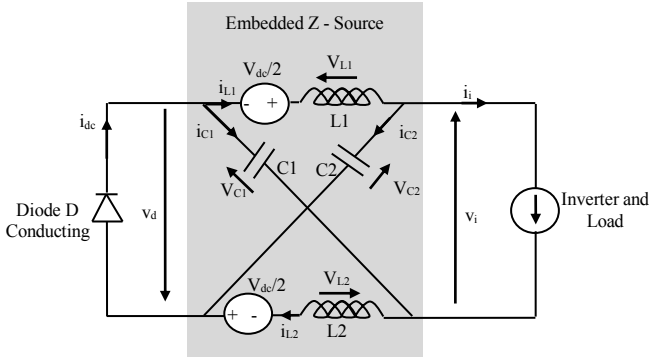

Fig.6. Equivalent circuit of two-level EZ-source when in non shoot-through state

The equivalent circuit of EZSI during non shoot through state is shown in Fig.6. During the shoot through active state (or) null state the diode D is conducting, the inverter bridge and external load are replaced by a current source. The value of current source is non zero for active state and zero for null state.

The following equations can be written from the equivalent circuits shown in Fig.3 and Fig.4 as expressed in [11].

Active state:

The inverter is operated in one of its six active states. The diode D is forward biased. The load and the Inverter Bridge are replaced by the current source as shown in Fig.6.

(The switches $S_x \neq S_x'$, $x = A, B, \text{ or } C$; $D = \text{ON}$. For time interval T1)

$$V_L = V_{dc}/2 - V_C \quad V_i = V_C - V_L + \frac{V_{dc}}{2} = 2V_C$$

$$V_d = V_D = 0 \quad (1)$$

$$i_{dc} = i_L + i_C \quad i_i = i_L - i_C \quad (2)$$

Nonshoot-Through zero state:

Inverter Bridge is operating in any one of its two nonshoot-through zero states. Inverter short circuits the load through either upper or lower three switches. The bridge can be viewed as an open circuit. The input DC voltage appears across the inductor and capacitor. But no inverter output current flows to the load.

During nonshoot-through zero state the switches $S_x \neq S_x'$, $x = A, B, \text{ or } C$; $D = \text{ON}$.

$$V_L = V_{dc}/2 - V_C \quad V_i = 2V_C \quad V_d = V_D = 0 \quad (3)$$

$$i_{dc} = i_L + i_C \quad i_i = 0 \quad i_{dc} \neq 0 \quad (4)$$

Shoot-through zero state:

Shoot through zero state is possible by seven different ways. Without disturbing the active states, shoot-through state is allocated into each phase within total zero time. The front-end diode D is reverse biased. The inverter is viewed as a short circuit from its DC link. There is no voltage across the load but the capacitor voltage is boosted

based on the shoot through duty ratio. (The switches $S_x = S_x' = \text{ON}$, $x = A, B, \text{ or } C$; $D = \text{OFF}$. For time interval (T0)

$$V_L = V_C + V_{dc}/2 \quad V_i = 0 \quad V_d = V_D = -2V_C \quad (5)$$

$$i_L = -i_C \quad i_i = i_L - i_C \quad i_C = 0 \quad (6)$$

The DC link voltage and peak AC voltage can be expressed by performing the state space averaging results in

$$V_C = \frac{V_{dc}/2}{1 - 2T_0/T}$$

$$\hat{V}_i = \frac{V_{dc}/2}{1 - 2T_0/T} = BV_{dc}$$

$$\hat{V}_{AC} = M \frac{\hat{V}_i}{2} = \frac{MV_{dc}}{2(1 - 2T_0/T)} = B \left(\frac{MV_{dc}}{2} \right) \quad (7)$$

EZSI produces same voltage gain as that of ZSI, the embedded sources within the impedance network provides inherent filtering. The voltage across the capacitor is fraction of that in ZSI [1], thus a significant reduction in capacitor sizing. When the modulation index M is set close to unity reduction in capacitor size is as 50% under normal condition and T0/T is kept small. Embedded sources help to maintain required voltage level within impedance network with lower voltage across the capacitor [12].

4. SPWM Control

The output voltage of Voltage Source Inverter is controlled by many PWM control techniques [7]. Among all the PWM techniques Sine PWM is commonly used to control the output voltage of VSI. PWM pulses generated from Sinusoidal Pulse Width Modulation technique.

The voltage source inverter has six active states, during which the DC voltage is immersed across the load, and two null states when the load terminals shorted through the lower or upper switches. The EZ-source inverter has additional state called shoot through zero state is possible when the upper and lower switches any one of the phase leg, any two phase leg, or all three phase are gated on simultaneously like Z-source inverter. Inserting the shoot through zero states within the switching cycle is the key point of the PWM control methods for the EZ-source inverter. In sinusoidal PWM, three phase sinusoidal modulating signals with 120 degree phase shift are compared with triangular carrier signal, the intersection of the two signals generate switching waveform to trigger the switching devices of the inverter circuit. The shoot through periods are generated by comparing the carrier signal and sinusoidal reference signal, and then inserted within the switching waveform depending upon the technique used.

In this paper Maximum boost control (MBC) method is proposed, in which the six active states are unchanged and all zero states are turned into shoot-through zero states, thus for any given modulation index the maximum shoot-through and boost factor can be obtained. It is important to reduce the voltage stress for a desired voltage gain to control the Z-source inverter. From the analysis of Z-source inverter [9], the voltage gain is $M \cdot B$, and the voltage stress across the switching device is $B \cdot V_{dc}$, in order to reduce the voltage stress and obtain the required voltage gain, B can be decreased and M can be increased. But to achieve maximum voltage gain for a given modulation index, B should be increased. From the above discussion we can have shoot-through duty ratio as large as possible for a desired voltage gain with reduced voltage stress. Fig.7. shows the PWM pulses along with shoot-through zero states.

The circuit is in its shoot-through state when the carrier triangular signal is greater than the peak curve of the sinusoidal reference signals V_a, V_b and V_c or lesser than the references. The shoot-through period repeats periodically in every $n/3$ degrees and it varies with each switching cycle. Having the switching frequency is much higher than the modulation frequency, the average shoot-through duty ratio over one switching cycle in the time interval of $\pi/6, \pi/2$ is given by [9]

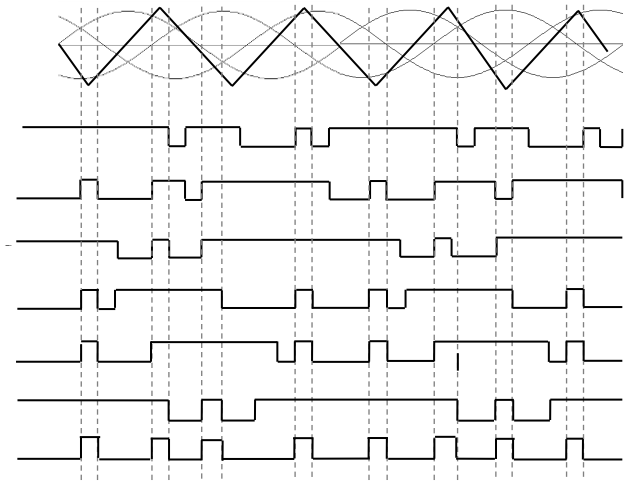

Figure.7. Sine PWM with shoot-through states

The circuit is in its shoot-through state when the carrier triangular signal is greater than the peak curve of the sinusoidal reference signals V_a, V_b and V_c or lesser than the references. The shoot-through period repeats periodically in every $n/3$ degrees and it varies with each switching cycle. Having the switching frequency is much higher than the modulation frequency, the average shoot-through duty ratio over one switching cycle in the time interval of $\pi/6, \pi/2$ is given by [max.boost.control]

$$D_0 = \frac{2\pi - 3\sqrt{3}\pi}{2\pi} \quad (8)$$

The Boost factor is given by

$$B = \frac{1}{1 - 2D_0} = \frac{1}{1 - 2\frac{T_0}{T}} \quad (9)$$

The relationship of gain and modulation index,

$$G = \frac{M}{1 - 2D_0} = \frac{M\pi}{3\sqrt{3}M - \pi} \quad (10)$$

5. Simulation Results and Discussions

The circuit diagram of sine PWM controlled two level voltage type Embedded Z-source inverter fed three phase induction motor drive is shown in Fig.8. Two similar DC sources each of 24 volts are embedded within the LC impedance network. Simulation circuit for EZSI fed three phase induction motor is modeled and simulated using MATLAB/SIMULINK. The simulation is carried out with $L1 = L2 = 20$ mH, $C1 = C2 = 2200$ μ F, The voltage is boosted by the impedance network with shoot-through duty ratio $T_0/T = 0.33$, output voltage of EZ network is 96 volts and is shown in Fig.9. The output phase voltages V_{ph} are measured and is 90 V, shown in Fig.10. The speed of the motor increase with increase in voltage and settles at 1000 RPM, is shown in Fig.11. The FFT analysis of the inverter output voltage is done and the Total Harmonic Distortion (THD) of about 6.01% is

measured. The Harmonic Spectra is shown in Fig.12. The fifth harmonic is predominant and the higher order harmonics are negligible.

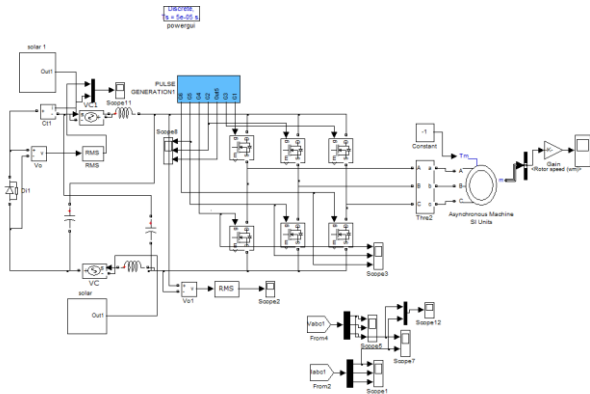

Figure.8. Simulation circuit of Sinusoidal pulse width modulated three phase induction motor drive.

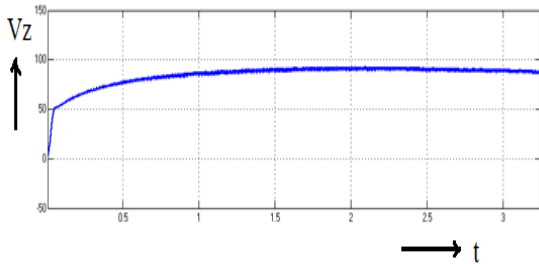

Figure.9. Output voltage of Embedded Z-Source

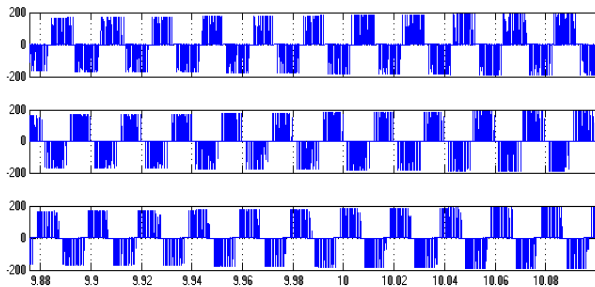

Figure.10. Output phase voltages of three phase EZSI

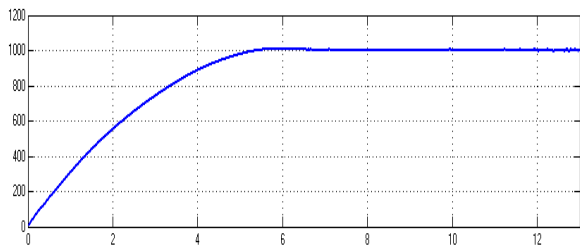

Figure.11. Motor Speed

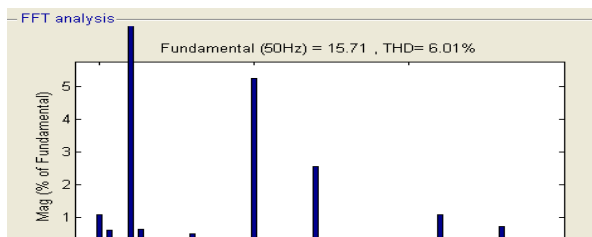

Figure.12. Harmonic Spectrum for Current

6. Experimental Results

The performance of the Sine PWM controlled EZSI fed three induction motor systems is implemented with the help of scaled down laboratory prototype system.

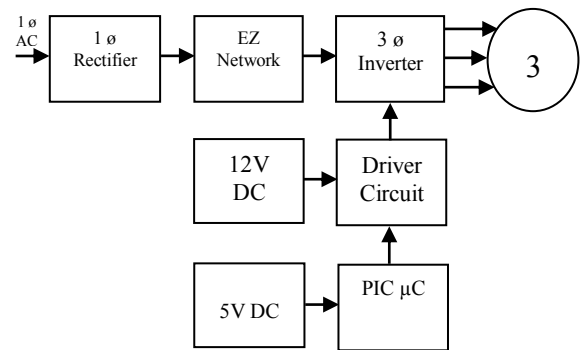

Fig.13. Block diagram of the EZSI fed three phase induction motor drive system

The performance of EZSI fed three phase induction motor drive is verified experimentally using hardware set up. The results obtained from experimental set up are presented. The block diagram of the hardware setup is shown in Fig.13. The hardware set up for EZSI fed induction motor drive is shown in Fig.14. The power source has two step down transformers of 230V/24V. This AC voltage is converted into DC by two separate diode bridge rectifier circuit. These two DC voltage source each of 24V are connected within EZ network to form the two-level voltage type converter. The total input voltage is 48 volts.

EZ network is constructed with L&C components of value $L1=L2=16\text{ mH}$, $C1=C2=2200\text{ }\mu\text{F}$

Two DC voltage source each of 24V are connected within EZ network to form the two-level voltage type converter. Voltage Regulator IC 7812 supplies 12V to the driver circuit, and voltage regulator IC 7805 provides 5 V to PIC Microcontroller unit.

The switching pulses are generated and controlled by PIC MICRO CONTROLLER 16F84. PIC MICRO CONTROLLER is programmed to generate sin PWM pulses with shoot through zero states. Three Driver ICs (IR2110) are used to drive the gating signals from microcontroller to respective gate terminals

of the switching devices, they amplify the 5V signal from microcontroller into 10 V. The driver IC consists of opto coupler. The MOSFETs IRF840 are used to construct the three phase inverter. Three phase induction motor of 0.5HP, is fed from the Embedded Z-Source Inverter. The DC source voltage is shown in Fig.15. The EZS network voltage 75V is measured and is given in Fig.16. The output phase voltage of inverter 70V is measured which is given in Fig.17. The output line to line voltage is shown in Fig.18. It can be seen from section V and VI that the experimental results match with simulation results of SPWM-EZSI-IMD system.

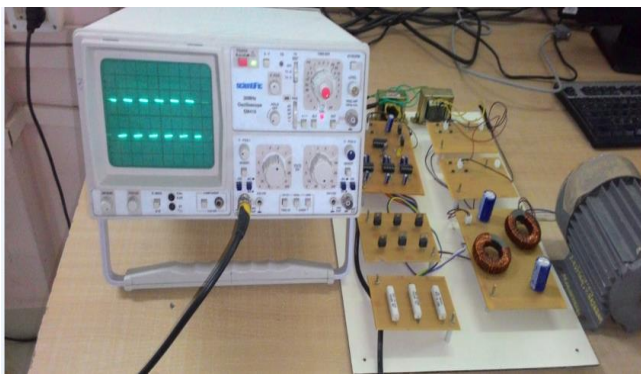

Figure.14.Hardware Implementation of EZSIIM System



Figure.15. DC Source Voltage

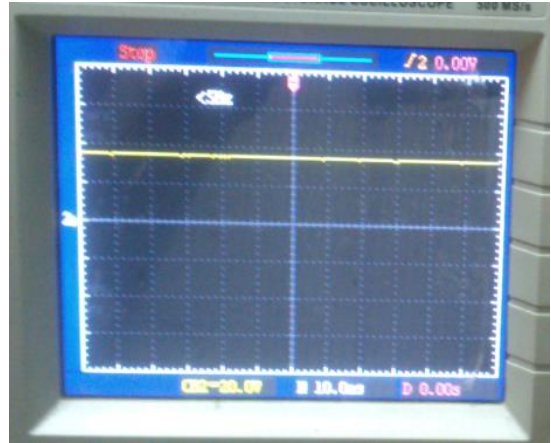

Figure.16. Output voltage of EZS Network



Figure.17.Phase Voltage



Figure.18. Line to Line Voltage

Table 1. Simulaltion Parameters

| Parameters | Value |
|----------------|--------------|
| Vin | 48V |
| L1 | 15mH |
| L2 | 15 mH |
| C1,C2 | 2200 μ F |
| MOSFET(IRF840) | 500V/8A |
| DIODE | 230V/1A |
| Duty ratio | 33% |
| V0 | 96V |

Table 2. Hardware Parameters

| Parameters | Value |
|----------------|--------------|
| Vin | 48V |
| L1 | 15mH |
| L2 | 15 mH |
| C1,C2 | 2200 μ F |
| MOSFET(IRF840) | 500V/8A |
| DIODE | 230V/1A |
| Duty ratio | 33% |
| V0 | 86V |

7. Conclusion

This paper has presented the PWM controlled embedded Z source inverter-fed three phase induction motor drive. The embedded z source inverters have the advantages of drawing smooth current from its DC source. The two input DC sources are embedded within wipid in network. L&C components present in the EZ network provide inherent filtering capability.

The operating principle, analyses, simulation results and prototype model of EZ inverter fed three phase induction motor are presented. The EZ source inverter overcomes the problems presented in VSI and CSI fed induction motor drives. Thus sine PWM controlled three phase induction motor drives implemented and favorable results have been obtained.

1. Two DC voltage source embedded within LC impedance network, provided smooth, desired DC voltage.
2. Due to the buck-boost operation of EZSI, provide ride though capability during voltage sags.
3. Sin PWM controlled EZSI produces output with reduced harmonics.

Therefore the new sine PWM controlled EZSI fed three phase induction motor is suitable for industrial drive applications.

Closed loop controlled EZSI-IMD system can be investigated in future. The proposed system can be operated at high power level.

REFERENCES

1. Fang Zheng Peng : "Z-Source Inverter", *IEEE Transactions on Industry Applications*, Vol. 39, No.2, March/April 2003.
2. P.C.Loh.D.M, Vilathgamuva, L.T.Wong : and C.P.Ang, "Z-source current-type inverters: Digital modulation and logic implementation," in Proc.IEEE IAS 2005, pp. 940-947.
3. Fang Z. Peng, Xiaoming Yuan, Xupeng Fang, and Zhaoming Qian : "Z-Source inverter for adjustable speed drives," *IEEE Power Electronics Letter.*, vol. 1, no.2, pp. 33-35, June.2003.
4. Dong Cao, Shuai Jiang, Xianhao Yu and Fang Zheng Peng, : "Low-cost semi-Z-Source inverter for single-phase photovoltaic systems," *IEEE Trans. Power Electron.*, vol. 26, no.12, pp. 3514-3523, Dec.2011.
5. Dong Sun, Boaming Ge, Fang Zheng Peng, Abu Rub Haitham, Dqiang Bi, Yushan Liu : " A new grid-connected PV system based on cascaded H-bridge Quasi-Z-Source inverter," *IEEE Power Electron. Conf.*, pp.951-956, 2012.
6. Fang Zheng Peng, Miaosen Shen, Kent Holland, : "Application of Z-Source inverter for traction drive of fuell cell-battery Hybrid Electric Vehicles," *IEEE Trans. Power Electron.*, vol. 22, no.3, pp. 1054-1061, May.2007.
7. P.C.Loh., 20, no 6, pp. D.M. Vilathgamuva, Y.S. Lai, : G.T. Chua, and Y.W. Li, "Pulse-width modulation of Z-source inverters," *IEEE Trans. Power Electron.*, vol 1346-1355, Nov.2005.
8. M.S. Shen, J. Wang, A.Joseph, F.Z.Peng, L.M. Tolbert, and D.J. Adams, : "Constant boost control of the Z-source inverter to minimize current ripple and voltage stress," *IEEE Trans Ind. Appl.*, vol. 42, no.3, pp. 770-777, May/June. 2006.
9. F.Z. Peng, M. S. Shen, and Z. Qian, : "Maximum boost control of the Z-source inverter," *IEEE Trans. Power Electron.*, vol. 20, no. 4, pp. 833-838, Jul. 2005.
10. Yushan Liu, Baoming Ge, Haitham Abu-Rub and Fang Zhang Peng : "Overview of space vector modulations for three-phase Z-source/Quasi-Z-source inverters," *IEEE Trans. Power Electron.*, vol. 29, no. 4, Apr.2014.
11. P.Rama Mohan, T.Brahmananda Reddy, M. Vijaya Kumar : *A Simple Generalized PWM Algorithm for Three Phase Voltage Source Inverter fed AC Drives*, *International Review of Electrical Engineering*, vol.10 , no. 2, 2015.
12. Chiang, Loh, "Embedded EZ-source inverters," *IEEE Trans. Ind.Appl.* vol. 46, no. 1, PP. 256-267, Jan/Feb.2010.
13. F.Gao, P.C. Loh, F.Blaabjerg and C.J.Gajanayake, : "Operational analysis and comparative evaluation of Embedded Z-source inverters," *IEEE conf.*2008.

14. F.Gao,P.C.Loh,D.Li, and F.Blaabjerg,: "*Asymmetric and Symmetric Embedded EZ-source inverters,*" IET Power Electron.vol.4, no.2, pp. 181-193,2011.
15. Minh-Khai Nguyen and Young-Cheol Lim,: "*Embedded Switched-Inductor Z-Source Inverters*" Journal of Power Electronics, Vol.13, No.1 , January 2013.
16. K.Srinivasan,T.Vijaykumar,: "*Practical Implementation of Embedded Controlled Reduced Switch Z-Source Inverter fed Induction Motor Drive*", Circuits and Systems, 2189-2195, July 2016.
17. D.Uma,K.Vijayarekha,: "*Modeling and Simulation of VSI Fed Induction Motor Drive in matlab/Simulink,*" International Journal of Electrical and Computer Engineering, Vol. 7, No. 2, April 2017, pp. 584~595