

Proportional-Resonant Controllers. A New Breed of Controllers Suitable for Grid-Connected Voltage-Source Converters

Remus Teodorescu, Frede Blaabjerg,

Aalborg University, Institute of Energy Technolog, Dept. of power electronics and drives
Pontoppidanstraede 101, 9220 Aalborg East, e-mail: ret@iet.auc.dk

Marco Liserre

Polytechnic of Bari, Dept. of Electrotechnical and Electronic Eng.
70125-Bari, Italy, e-mail: liserre@poliba.it

Abstract—This paper is describing the recently introduced proportional-resonant (PR) controllers and their suitability for grid-connected converters current control. It is shown that the known shortcomings associated with PI controllers like steady-state error for single-phase converters and the need of decoupling for three-phase converters can be alleviated. Additionally, selective harmonic compensation is also possible with PR controllers. Suggested control-diagrams for three-phase grid converters and active filters are also presented. A practical application of PR current control for a photovoltaic (PV) inverter is also described.

Index Terms - current controller, grid converters, photovoltaic inverter

I. INTRODUCTION

During the last few years, it has been observed an increased focus in the development of distributed power generation with renewable energy sources like wind, water and solar energy. All these systems include a grid-connected converter with the function of synchronizing and transfer of the variable produced power over to the grid.

The typical solution for the grid converter is PWM current-controlled voltage-source converter in both single-phase and three-phase systems.

New power quality standards for distributed generation in the low voltage grid like IEEE-1547 in US and IEC61727 in Europe impose very stringent limits for the current harmonics.

Typically, PI controllers with grid voltage feed-forward are used in order to control the current of grid-connected converters [1]. The known drawbacks are the difficulty in removing the stationary error in stationary frame controllers for single-phase systems, the need of decoupling in three-phase systems and in general the limitations in compensating the low harmonics in order to comply with the power quality standard. Another shortcoming is due to the presence of background harmonics in the feed-forwarded grid voltage that has negative influence for the current.

Generally speaking, PI control is unable to remove the low current harmonics due to the bandwidth limitation. In order to increase the bandwidth it would be required such a high proportional gain that the

stability of the system becomes a critical issue. Especially when LCL filters are used to attenuate the switching ripple the stability problem is difficult to solve as higher gains could excite resonance and lead to instability as reported in [2].

For three-phase systems proportional integral (PI)-dq control with voltage feed-forward is commonly used and it requires a lot of transformations to change the reference frame increasing so the complexity of the implementation, especially when low-cost fixed-point DSP technology is used.

Thus the need for a different control structure exhibiting better performances and lower implementation burden has become very actual.

In order to alleviate these problems, a second order generalized integrator (GI) as reported in [3] can be used. The GI is a double integrator that achieves an infinite gain at a certain frequency, also called resonance frequency, and almost no attenuation exists outside this frequency. Thus, it can be used as a notch filter in order to compensate the harmonics in a very selective way.

This technique has been primarily used in three-phase active filter applications as reported in [3] and also in [4] where closed-loop harmonic control is introduced.

Another approach reported in [5] where a new type of stationary-frame regulators called P+Resonant (PR) is introduced and applied to three-phase PWM inverter control. In this approach the PI de-compensator is transformed into an equivalent ac-compensator, so that it has the same frequency response characteristics in the bandwidth of concern.

Combined current control and selective harmonic compensation using resonant controller in single-phase PV inverters is reported in [6], where it has been shown that the voltage feed-forward can be eliminated without decreasing the performances. Finally, the same technique is reported in [6] for the control of PWM rectifier in single-phase high-power traction systems

Typically, the grid converters are used in many applications like renewable energy systems (RES) or active rectifiers. In all these applications, the function

of the grid converter has a lot in common: should control the current, synchronize it with the grid and control the dc voltage. As the reference is always sinusoidal, the PR technique can be successfully used.

In this paper the PR controllers are introduced and the performances are described using frequency analysis. Then, typical control strategies for both single-phase and three-phase RES using PI and PR are described and compared in terms of performance and ease of implementation.

Finally, the experimental results of using PR controller and selective harmonic compensation with a single-phase PV inverter are presented

II. THE PROPORTIONAL RESONANT CONTROLLER

The P+Resonant (PR) current controller is defined as [3],

$$G_c(s) = K_p + K_i \frac{s}{s^2 + \omega^2} \quad (1)$$

The Bode plots of PR (1) are shown in Fig. 1 for $K_p=1$, $\omega = 2\pi 50$ and $K_i=1, 10$ and 100.

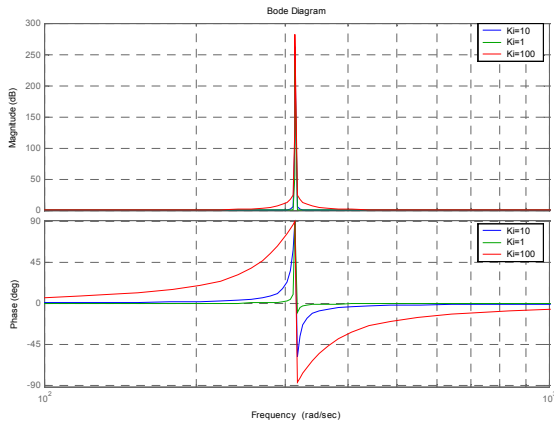

Fig. 1. Bode graph of PR controller

As it can be seen, it achieves very high gain in a narrow frequency band centered around the resonance frequency. The width of this frequency band depends on the integral time constant K_i . A low K_i leads to a very narrow band while a high K_i leads to a wider band. Thus the PR can be tuned according to the needs. For example in grid applications the grid frequency is typically constant, but still it is allowed to vary with ca. 1%. So in order to make the PR to react to this frequency band, an appropriate K_i can be found by running frequency analysis.

The second term in (1) is actually a generalized integrator (GI) [3] and it will integrate a sinusoidal input with respect to the time without introducing any phase-delay., as shown in Fig. 2

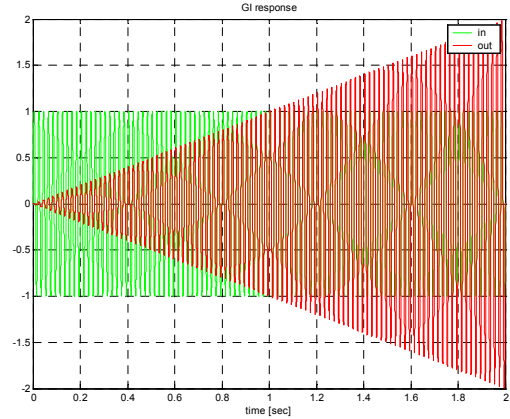

Fig. 2. Input and output of GI

Thus a PR controller has much in common with a common PI controller. The difference consists only in the way the integration action takes part. The integrator will only integrate frequencies very close to the resonance frequency and will not introduce stationary error or phase shift.

The proportional gain K_p is tuned in the same way as for the PI controller. Basically it determines the dynamics of the system in terms of bandwidth phase and gain margin [3]. For harmonic compensation, it determines the order of harmonics that can be regulated without violating the stability limit.

Selective harmonic compensation can be achieved by cascading several GI tuned to resonate at the desired frequency. In (2), the transfer function of a typical harmonic compensator (HC) designed to compensate the 3rd, 5th and 7th harmonics as they are the most prominent harmonics in the current spectrum, is given:

$$G_h(s) = \sum_{h=3,5,7} K_{h} \frac{s}{s^2 + (\omega \cdot h)^2} \quad (2)$$

An interesting feature of the HC is that it does not affect the dynamics of the PR controller, as it only reacts to the frequencies very close to the resonance frequency [3].

Thus the PR technique can be successfully used in current control for grid-converter applications where the requirements are to synchronize the current with the constant grid frequency and to compensate for the low harmonics. In the followings, some typical employments of PR controllers in three-phase and single-phase (RES) are described.

III. APPLICATION OF PR CONTROLLERS TO THREE-PHASE GRID-CONVERTERS

Three-phase grid converters are commonly used in applications like RES (small wind or water turbines, high-power PV plant, etc), residential UPS, active filters, etc. In Fig 3 a typical RES is depicted where the active and reactive powers are controlled in the outer loop.

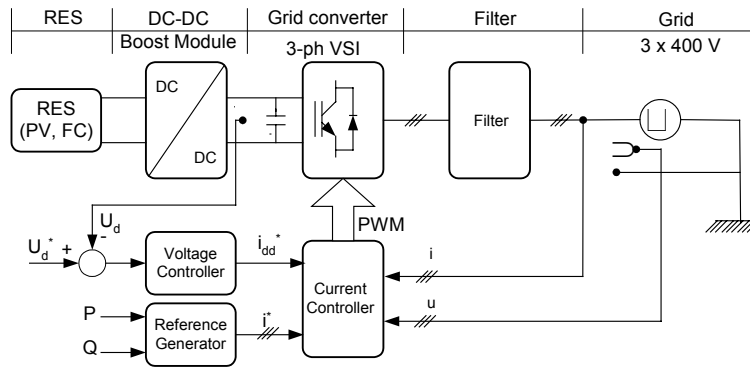

Fig. 3 The block diagram of a typical three-phase RES

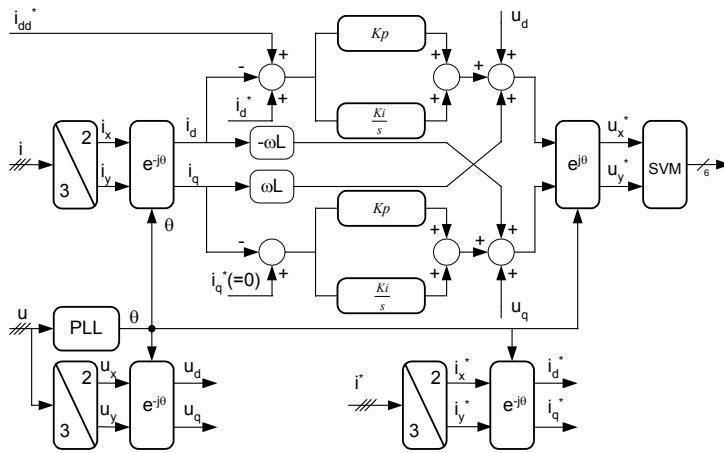

Fig. 4. Synchronous PI-dq current control for three-phase voltage-source grid-converters

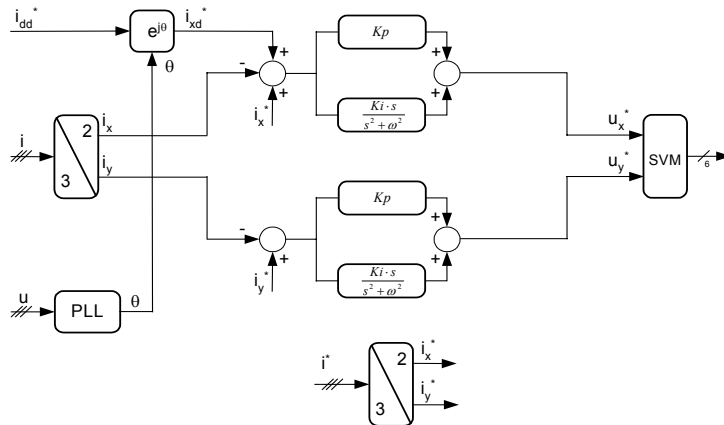

Fig. 5. Stationary PR current control for three-phase voltage-source grid-converter

For the internal current loop, synchronous PI-dq current control scheme [1] is typically used as depicted in Fig.4. As it can be seen, the algorithm requires quite a lot of calculations like coordinate transformations from abc to xy and rotation with θ in order to have the currents in synchronous frame where they become dc values and so PI controllers can be successfully used.

Cross-couplings between d and q axis are required due to the coordinates transformations and voltage feed-forward is used to improve the dynamic response.

A PLL is commonly used in order to determine the phase angle of the grid θ and use it for the current reference in order to achieve synchronism between the two power sources.

The active power transfer is controlled by the d -current and the reactive power by q -current. Typically, the q -current reference is set to null as unity power factor is required by power quality standards.

In order to control the dc voltage U_d that is influenced by the active power balance, a dc-voltage controller is typically used, whose output i_{dd}^* is added to the d -current reference [1]

The output of the current controller becomes the converter voltage reference u^* and used as input for a space vector modulation (SVM) block to generate the PWM gate signals.

In Fig. 5, a current control scheme in stationary reference frame using PR controllers is proposed.

As it can be observed, the complexity of the calculations has been significantly reduced as there is no more need for voltage feed-forward and rotation with θ is only required for the i_{dd}^* in order to move it in stationary reference frame. Cross-couplings are also removed.

Thus a higher degree of ease in implementation can be achieved.

In order to implement the PR in digital systems appropriate discretization must be found. As shown in [6] the GI can be transformed in the equivalent form (3):

$$\frac{y(s)}{u(s)} = \frac{s}{s^2 + \omega^2} \Leftrightarrow \begin{cases} y(s) = \frac{1}{s} [u(s) - v(s)] \\ v(s) = \frac{1}{s} \cdot \omega^2 \cdot y(s) \end{cases} \quad (3)$$

where it has been decomposed in two simple integrators as depicted in the block diagram in Fig. 6

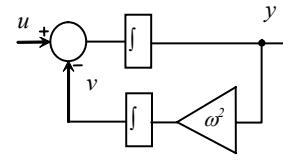

Fig. 6. GI decomposed in two simple integrators

This means that the discretization is much simplified as two simple integrators are used.

Additionally, harmonic compensators can be cascaded as depicted in Fig. 7 in order to improve the THD.

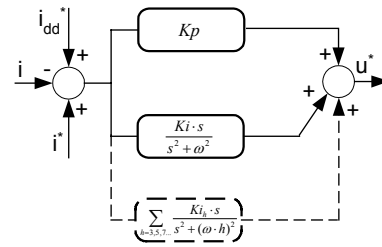

Fig. 7. Stationary PR control with selective harmonic compensation

Thus, the PR technique can be used with success to three-phase grid converters replacing the common synchronous PI-dq control

IV. APPLICATION OF PR CONTROLLERS TO SINGLE-PHASE GRID-CONVERTERS

Single-phase grid converters are commonly used in applications like residential RES (typically PV or FC systems), residential UPS, etc. In Fig 8 a typical RES is depicted where the active and reactive power is controlled in the outer loop

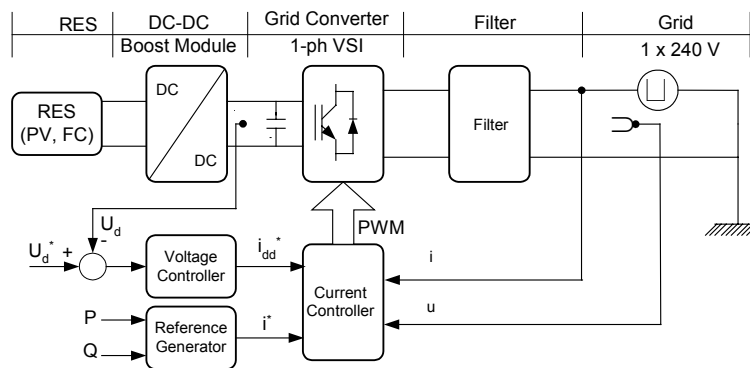

Fig. 8 The block diagram of a typical 1-ph RES system



Fig. 9. Stationary PI (left) and stationary PR (right) current control for single-phase voltage source grid converters

Typically stationary PI current control scheme with voltage feed forward is used as depicted in Fig. 9, but this solution leads to stationary error in tracking the sinusoidal input and poor harmonic compensation is achieved as reported in [6]. Synchronous PI-dq control is very difficult to achieve as it is a single-phase system.

Instead, PR technique can be used for the current controller as shown in Fig. 9. As it can be observed, the voltage feed-forward has been removed simplifying thus the implementation. The implementation of the GI adds an extra integrator in comparison with standard PI but as shown in [6] the extra burden for a low cost 16-bit fixed point DSP can be ignored

As for the case of three-phase systems, HC can be easily cascaded in the manner shown in Fig. 6 in order to improve the harmonic compensation

V. PRACTICAL APPLICATION OF PR CONTROLLERS TO SINGLE-PHASE PV INVERTER

A test set-up consisting of a 3 kW PV full-bridge inverter with LCL filter has been built. The block diagram is depicted in Fig. 10.

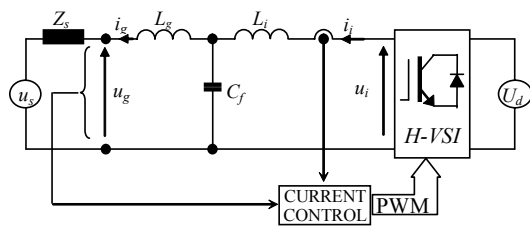

Fig. 10. Block diagram of experimental set-up for PV inverter

The following equipment is been used: 400V/10A regulated dc power supply to simulate PV panels string, digital scope Tektronix TDS3014B and power analyser PM100, as depicted in Fig. 11.

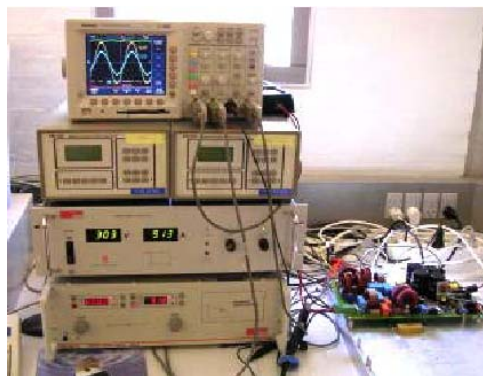

Fig. 11 Experimental test set-up for the 3kW PV inverter

The grid voltage and current was measured using Tektronix differential probe TP5205 and current probe TCP202 respectively.

The system was tested in the following conditions: dc voltage $U_D = 350$ V, grid voltage $U_g = 230$ V_{RMS} with a THD of 1.46 % background distortion.

The grid current and grid voltage at 50% load for PR, and PR+HC controllers are shown in Fig.12 and Fig.13 respectively

The PR controller uses $K_p = 2$ and $K_i = 300$ and $K_{ih} = 300$ for $h = 3,5,7$ for the harmonic compensator.

The control strategy has been implemented and tested on a 16-bit fixed-point TMS320F24xx DSP platform. The execution time for the control loop was measured to about 40 μ s, for the PR including the harmonic compensator

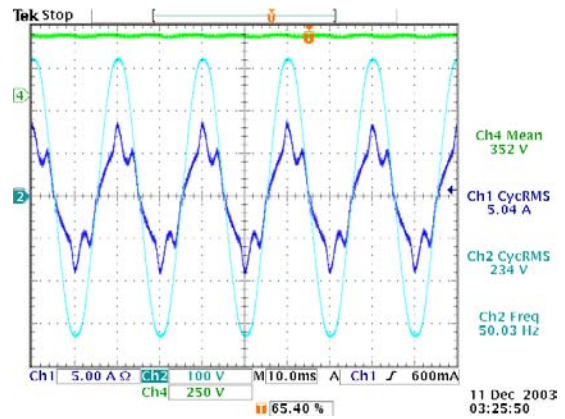

Fig. 12. Test with PR controller at 50% load . Grid voltage -Ch2 [100V/div], grid current-Ch1[5A/div] and DC voltage-Ch4[250V/div]

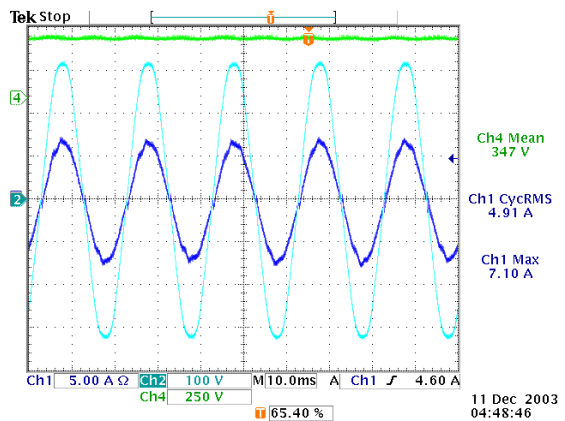

Fig. 13. Test with PR+HC controller at 50% load . Grid voltage - Ch2 [100V/div], grid current-Ch1[5A/div] and DC voltage-Ch4[250V/div]

As it can be easily observed in Fig. 12, no phase error can be seen between the current and the grid voltage confirming thus that the PR controller works properly.

In Fig. 13, a significant compensation of the harmonics can be observed confirming the effective use of resonant controllers for harmonic compensation

VI. CONCLUSIONS

In this paper the proportional-resonant controllers (PR) are introduced and their suitability for current control in both single-phase and three-phase grid converters is demonstrated.

They can be tuned to react to a certain frequency that can be chosen to be equal with the grid frequency for a good regulation of the fundamental current and they can be tuned to the harmonic frequency in order to compensate them.

The PR technique can successfully replaced the typical PI-dq control scheme for three-phase systems exhibiting some advantages like reduced complexity and improved harmonic rejection capability.

Also, for single-phase systems it can replace stationary PI control showing better performances in terms of steady-state error and harmonic rejection

REFERENCES

- [1] M. Kazmierkowski, R.Krishnan, F.Blaabjerg, Control in Power Electronics. Selected Problems, Academic Press 2002, ISBN 0-12-402772-5.
- [2] R. Teodorescu, F. Blaabjerg, M. Liserre and A. Dell'Aquila "A stable three-phase LCL-filter based active rectifier without damping" IAS 2003, pp. 1552 – 1557.
- [3] X. Yuan, W. Merk, H. Stemmler, J. Allmeling – "Stationary-Frame Generalized Integrators for Current Control of Active Power Filters with Zero Steady-State Error for Current Harmonics of Concern Under Unbalanced and Distorted Operating Conditions" *IEEE Trans. on Ind. App.*, vol. 38, no. 2, Mar./Apr. 2002, pp.523 – 532.
- [4] P. Mattavelli "A Closed-Loop Selective Harmonic Compensation for Active Filters" *IEEE Trans. on Ind. App.*, vol. 37, no. 1, January/February, 2001, pp. 81 – 89.
- [5] D. N. Zmood, D. G. Holmes, "Stationary Frame Current Regulation of PWM Inverters with Zero Steady-State Error" *IEEE Trans. on Power Electr.*, vol. 18, no. 3, May 2003, pp. 814 – 822.
- [6] Teodorescu,R., Blaabjerg,F., Liserre.M., Borup,U.,-" A New Control Structure for Grid-Connected PV Inverters with Zero Steady-State Error and Selective Harmonic Compensation" – Proceedings of APEC'04, Anaheim, CA.
- [7] H-S.S. Song, R.Keil, P.Mutschler, J.Weem, K.Nam – "Advanced Control Scheme for a Single-Phase PWM Rectifier in Traction Applications" IAS 2003, pp. 1558 –1565
- [8] M. Liserre, F. Blaabjerg, and S. Hansen, "Design and control of an LCL-filter based active rectifier," *IEEE Trans. on Ind. App.*, vol. 38, no. 2 Sept./Oct. 2001, pp. 299-307.
- [9] D.G. Holmes and T. Lipo, Pulse Width Modulation for Power Converters : Principles and Practice, 2003, ISBN 0471208140.