

SOGI-Q Based Control of Power Quality Enhancement in Solar PV Distributed Generation

Manikandan.P¹, Dr.S.P.Umayal²

¹Research Scholar, Anna University, Chennai, India. manisquare2007@gmail.com

²Principal, VPMM Engineering College for Women, Virudhunagar, India. umayalbabu@gmail.com

Abstract— A three-phase multifunctional grid supported solar energy generation system with a two stage circuit topology is proposed. A two stage circuit topology is divided as boost converter serving MPPT and as a grid tied four-leg VSC (Voltage Source Converter), which serves for feeding the extracted solar photovoltaic energy into the grid and also serves for power quality improvement. SOGI-Q (Second Order Generalized Integrator-Quadrature) based control algorithm is proposed for the control of this multifunctional four-leg VSC. A feed-forward term for the solar PV contribution is used to enhance the dynamic response for CPI voltage variation. Simulations have been done in SIMULINK software of MATLAB14a. The performance of the proposed control algorithm is validated through the simulation results.

Index Terms— MPPT; Power Quality; SOGI-Q; Solar PV; VSC

I. INTRODUCTION

Electricity has been considered as an important requirement for existence of human life. In order to avoid the lack of electrical energy several initiatives have been carried out and results are focused towards generation of electricity through renewable energy sources. The electrical energy from photovoltaic (PV) cells is considered as a natural energy source that is more useful, since it is free, abundant, clean, and distributed over the world. A grid tied solar energy conversion system is shown in [1].

Solar energy conversion system can be classified as standalone generating unit and grid connected generating unit depending on the availability of a grid nearby. In standalone PV system batteries become an integral part and they require frequent maintenance and timely replacement. Therefore, grid interfaced PV generation systems are mostly preferred. Standalone PV generation system with battery unit is shown in [2]-[3].

Solar PV characteristics are nonlinear and there is a unique operating point from which peak power can be extracted from a given PV array. This peak power point changes with varying climatic conditions, such as irradiance level and temperature. Several methods has been used for maximum power point tracking such as perturb and observe method, incremental conductance method, constant voltage method, fractional open circuit voltage, constant current method, etc. Various MPPTs and their power analysis are shown in [4]-[6]. In this paper, composite InC algorithm is proposed which is the combination of incremental conductance and fractional open circuit voltage MPPT algorithm.

Non-linear loads with power electronics devices are mostly used in grid utility system. The unbalanced operation of these loads may inject harmonics into the grid and causes several power quality problems at CPI. Harmonics may increase losses in electrical devices and cause malfunction to the

electrical system. To reduce the harmonic problem in the system several passive and active power filters (APF) has been implemented. Shunt APF is mostly used which is a power electronic converter based device which is intended to mitigate the PQ problem. Series and parallel active power filters used to mitigate the power quality issues are shown in [6]-[13]. The D-STATCOM (Distribution Static Compensator) provides an adaptive solution for these power quality problems. For the control of DSTATCOM several soft-computing- based control algorithms are proposed such as an adaptive theory-based strategy control and a complicated neural-network-based control strategy has been proposed as shown in [8]-[10].

In a three phase system, under a balanced linear load the current in the neutral conductor is zero. But with nonlinear loads at the CPI, all triplen harmonics and zero sequence currents flow through the neutral conductor. These neutral current increases losses in the distribution system and the excessive neutral current may burst neutral conductor. Comparison and analysis of different neutral current mitigation technique is shown in [11]. A zig-zag transformer based active filter for neutral current compensation is shown in [12].

The distribution generation (DG) system interfaced with VSC (Voltage Source Converter) is shown in [13] and [14]. The two stage solar energy generation system is shown in [13] and [14]. First stage is boost converter which serves for MPPT and next stage is VSC which feed the extracted PV power to the distribution system. SOGI control algorithm is used for generating an orthogonal set of voltage vectors in single-phase PLL's [15].

In this paper two stage distribution generation system is implemented. The first stage is boost converter which serves for peak power tracking from solar PV array. The second stage is four-leg VSC which feeds the extracted power from solar PV array to the distribution generation system and also serves

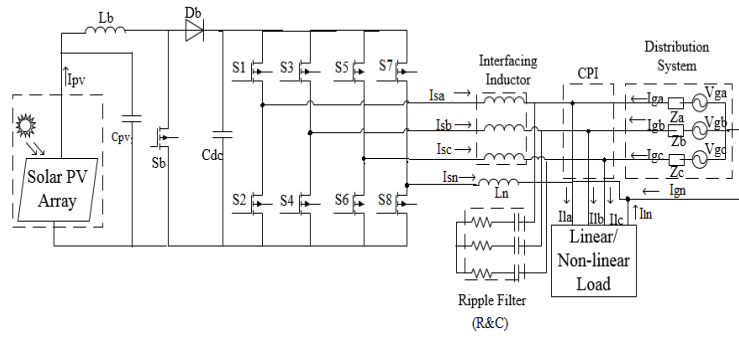

Fig. 1 System Configuration

for power quality improvement such as harmonic mitigation, grid current balancing and reactive power compensation. For the control of four-leg VSC SOGI-Q control algorithm is implemented. SOGI-Q-based control algorithm is used to with neutral current compensation. The main contribution of this work is given as

1. A composite InC control algorithm for boost converter is used to extract maximum power from the solar PV array.
2. SOGI-Q based control algorithm for four-leg VSC is implemented to diminish the neutral current in DG system.

II. SYSTEM DESCRIPTION

The system configuration of solar PV distribution generation system is shown in Fig. 1. The proposed system consists of solar PV array, boost converter, DC link capacitor, four-leg VSC, interfacing inductor, ripple filter(R&C), distribution system and linear and non-linear loads. The PV array is connected to the boost converter and maximum power is extracted from PV array by MPPT. The output of the boost converter is fed to the DC link capacitance. The input to the VSC is obtained from DC link capacitance. The output of the VSC is fed to the distribution generation system through interfacing inductor. The ripple filter is used to reduce the switching ripples in VSC. The VSC of the proposed system is also serves for power quality improvement. The control algorithm for VSC is shown in Fig. 2.

a. Design of Boost Converter

The boost converter consists of boost inductor, diode, capacitor and controlled switch. The boost converter is used to step up the input voltage to a higher magnitude output voltage. The parameter of boost converter is calculated as:

The DC capacitor voltage is determined from

$$V_{dc} = \frac{2\sqrt{2}V_L}{\sqrt{3}m} \quad (1)$$

where V_L = AC line voltage

The duty ratio for boost converter are calculated as,

$$D_R = \frac{V_{dc} - V_{spv}}{V_{dc}} \quad (2)$$

where V_{dc} = DC link voltage and V_{spv} =solar PV voltage

The inductance of the boost converter is obtained by,

$$L_b = \frac{V_{spv} \times D_R}{f \times \Delta I} \quad (3)$$

estimate the active power component of the load currents, which helps in fast dynamic response during load variation at the CPI. The four-leg VSC topology is used to enable connection with a four-wire distribution generation system

where f = frequency and $\Delta I = 1\%$ of I_{dc}

The DC link capacitor between the boost converter and voltage source converter is given by,

$$C_{dc} = \frac{P_{dc}/V_{dc}}{2 \times \omega \times V_{dcr}} \quad (4)$$

where V_{dcr} = DC ripple voltage and P_{dc} = DC output power.

b. Control Approach for Boost Converter

Composite InC control algorithm is implemented for the control of boost converter which is the combination of incremental conductance and fractional open circuit voltage based control algorithm. The range of voltage at peak power is obtained from fractional open circuit voltage algorithm lies between $0.7V_{ocmax}$ to $0.9V_{ocmax}$. The power slope of PV is zero ($dP/dV=0$), in the InC method at MPPT also it is noted that positive in the left and negative in the right. The duty ratio for the boost converter is estimated based on reference PV voltage and DC link voltage. The reference PV voltage is obtained from InC control algorithm. For calculation of incremental conductance ΔI and ΔV are estimated as

$$\Delta I = I(k) - I(k-1) \quad (5.a)$$

$$\Delta V = V(k) - V(k-1) \quad (5.b)$$

The governing equations for InC based MPPT algorithm is as,

$$\frac{\Delta I}{\Delta V} = -\frac{I}{V}, \text{ at MPP}$$

$$\frac{\Delta I}{\Delta V} > \frac{I}{V}, \text{ Left of MPP on P v/s V curve}$$

$$\frac{\Delta I}{\Delta V} < \frac{I}{V}, \text{ Right of MPP on P v/s V curve}$$

The reference duty ratio is used to generate the switching sequences for boost converter is given by,

$$D_{ref} = 1 - (V_{pvref}(k)/V_{dc}(k)) \quad (6)$$

c. Control Approach for VSC

For the control of VSC, line voltages (V_{sab} and V_{sbc}), DC link voltage V_{dc} , grid currents (i_{ga} , i_{gb} , i_{gc}), load currents (i_{La} , i_{Lb} , i_{Lc}), PV array voltage and PV array current have been sensed. From the sensed line voltages the phase voltages is determined and then the synchronization signals are estimated from the phase voltages.

The amplitude of phase voltages is determined as,

The feed forward term for PV array contribution in reference grid current is calculated from solar PV current and voltage.

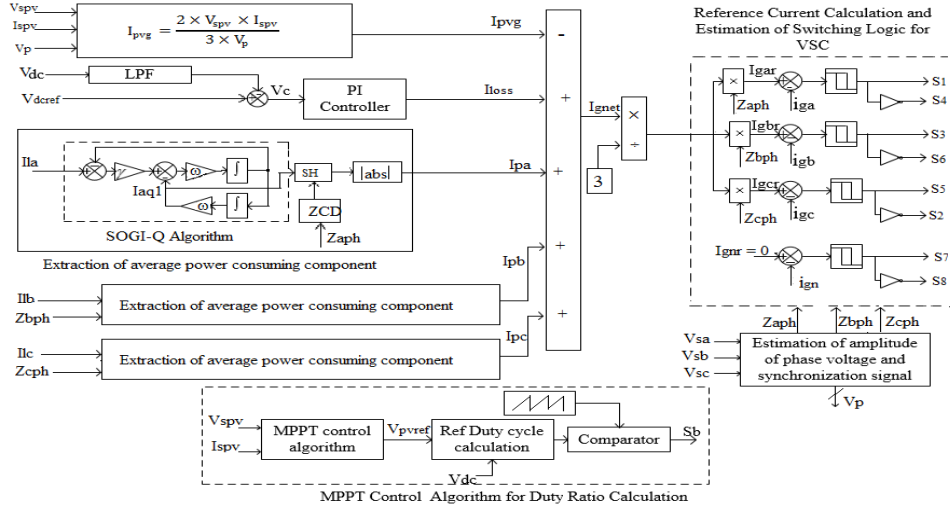

Fig. 2 Control Approach for VSC

$$V_p = \frac{\sqrt{V_{sa}^2 + V_{sb}^2 + V_{sc}^2}}{\sqrt{3}} \quad (7)$$

This peak voltage is used to determine the in-phase and quadrature unit vectors of CPI voltages, which contain the phasor information of all phase voltages. The in-phase unit vectors are estimated as,

$$Z_{aph} = V_{sa} / V_p \quad (8.a)$$

$$Z_{bph} = V_{sb} / V_p \quad (8.b)$$

$$Z_{cph} = V_{sc} / V_p \quad (8.c)$$

The quadrature unit templates are estimated as

$$Z_{aqt} = -Z_{bg}/\sqrt{3} + Z_{cp}/\sqrt{3} \quad (9.a)$$

$$Z_{bqt} = \sqrt{3}Z_{ap}/2 + (Z_{bp}-Z_{cp})/2\sqrt{3} \quad (9.b)$$

$$Z_{aqt} = -\sqrt{3}Z_{ap}/2 + (Z_{bp}-Z_{cp})/2\sqrt{3} \quad (9.c)$$

A SOGI-Q-based algorithm is used to estimate the average power-consuming component of load currents, which is determined independently for all three phases. Fundamental part of the load current is obtained by inserting the load current to SOGI block. The SOGI-Q block not only filters the load current for harmonics but also provides a phase shift of 90° to the fundamental component with respect to the actual load current. The transfer function of the SOGI-Q block is given as

$$F(s) = I_{aq1}(s)/I_l(s) = \gamma\omega^2/(s^2 + \gamma\omega s + \omega^2) \quad (10)$$

where ω is fundamental frequency. The active power component of the load current is as follows

$$Z_{ap1} = \sin(\omega t) \quad (11)$$

The fundamental current by the SOGI-Q can be represented as

$$\begin{aligned} I_{aq1} &= I_{ma} \sin(\omega t - \theta_a - \pi/2) \\ &= -(I_{ma} \cos\omega t \times \cos\theta_a + I_{ma} \sin\omega t \times \sin\theta_a) \end{aligned} \quad (12)$$

The sample and hold at every zero crossing can be expressed as

$$I_{aq1} = I_{ma} \sin(\omega t - \pi/2) = \pm(I_{ma} \cos\theta_a) \sin\omega t = 0 \quad (13)$$

The PV array contribution term PVFF (Photovoltaic Feed Forward) is given by,

$$I_{pgv} = \frac{2 \times V_{spv} \times I_{spv}}{3 \times V_p} \quad (14)$$

The load and loss components of all three phases are added to estimate the net power consumption at CPI, whereas the PV contribution term is subtracted from this component for estimation of the amplitude total average power-consuming component of the grid current which is given as,

$$I_{gnet} = I_{pa} + I_{pb} + I_{pc} + I_{loss} - I_{pgv} \quad (15)$$

The reference grid currents are estimated as,

$$I_{gar} = I_{gnet} \times Z_{aph}/3 \quad (16.a)$$

$$I_{gbr} = I_{gnet} \times Z_{bph}/3 \quad (16.b)$$

$$I_{gcr} = I_{gnet} \times Z_{cph}/3 \quad (16.c)$$

The sensed and reference currents are given as the inputs to the hysteresis current controller and logic switching pulses obtained from the current controller is given to VSC.

III. RESULT AND DISCUSSION

Performance analysis of the control algorithm is obtained from the MATLAB simulink model. Grid currents (i_{gabc}), load currents (i_{labc}), PV array voltage (V_{pv}) and current (I_{pv}), DC link voltage (V_{DC}) and VSC voltage (V_{sabc}) are sensed for the control approach.

TABLE.I SYSTEM SPECIFICATION

Parameters	Range
V_{pv}, V_{oc}	350 V, 600V
I_{sc}	60 A
V_{DC}	700 V
Interfacing Inductor	3 mH
Ripple Filter Resistor and Capacitor	R = 5 ohm, C = 5μF
Three Phase Grid Voltage and frequency	V = 415V, f=50 Hz
Supply Resistor and Inductor	R = 0.5 ohm, L = 2 mH
Linear Load Power	30 kW

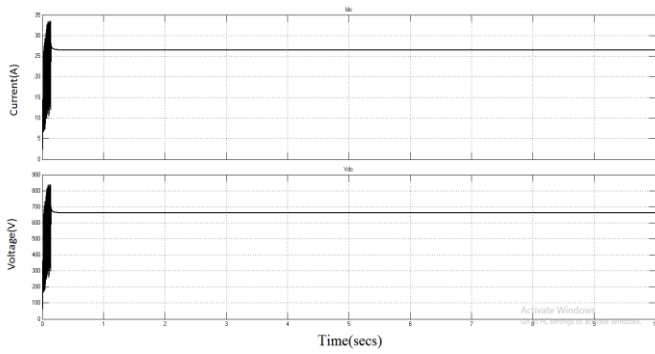
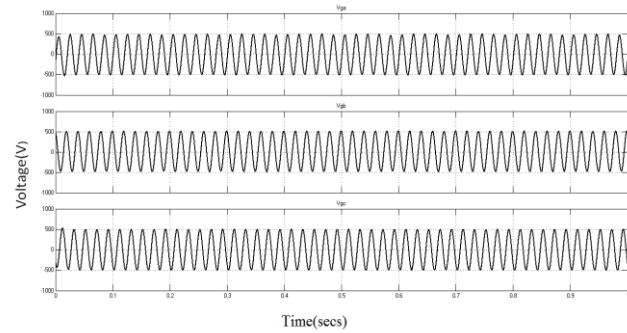
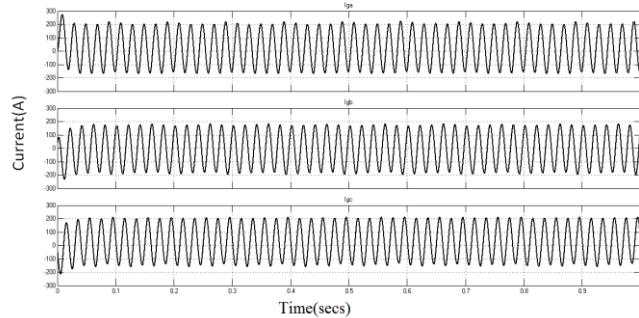

Fig. 3 DC Output Voltage and Current from Boost Converter

The Fig. 3 shows the output voltage and current from the boost converter with Composite InC control algorithm. The output voltage obtained from the boost converter is 700V across the DC link capacitor. The DC link capacitor regulates the dc voltage and then fed it to the VSC.



(a) Line Voltage of Distribution Grid System



(b) Grid Current

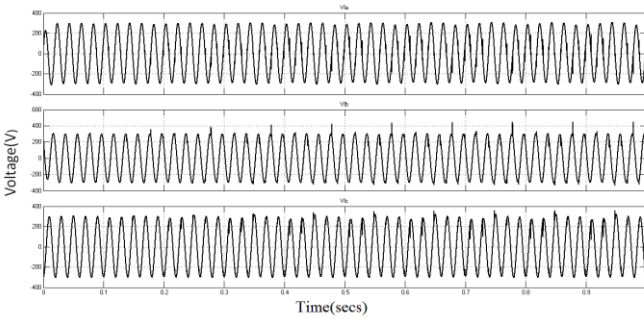

(c) Voltage at CPI with Linear and Non-Linear Load

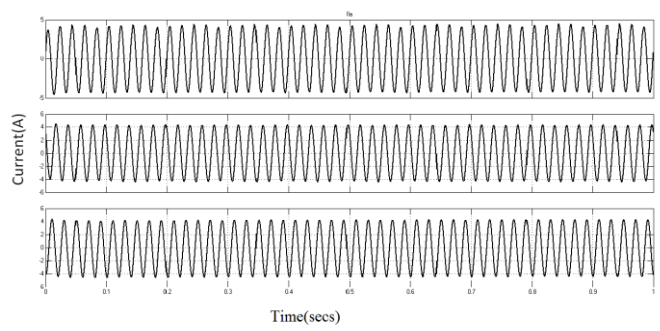

(d) Current at CPI with Linear Load
Fig. 4 Output current and voltage of DG interfaced solar system without control algorithm

The Fig.4 shows the output current and voltage of DG interfaced solar system without control algorithm. Figs. 4(a) & (b) show the distribution grid system voltage and current. It is observed that with control algorithm the grid currents are balanced. Figs. 4(c) & (d) show the output voltage and current of the load.

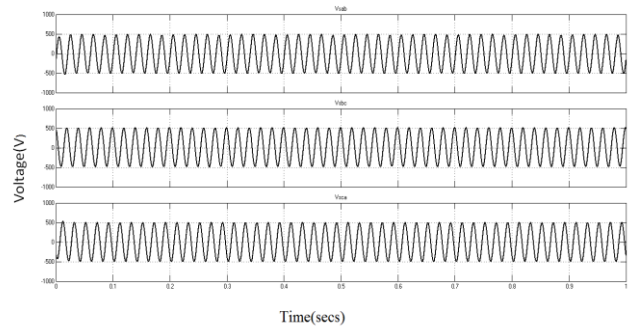

(a) Line Voltage of Voltage Source Inverter

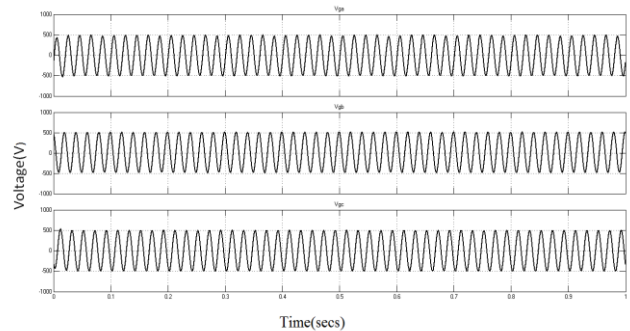

(b) Line Voltage of Distribution Grid System

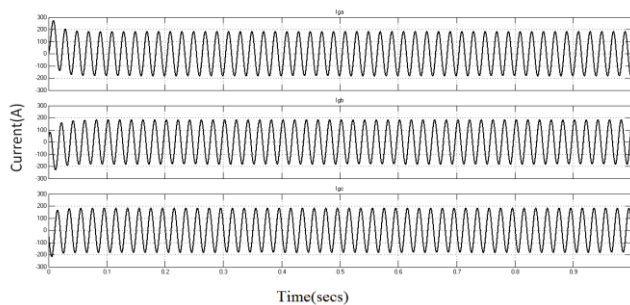

(c) Grid Current

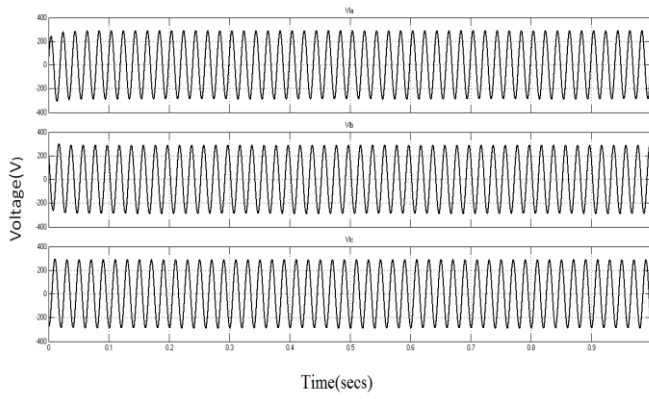

(d) Voltage at CPI with Linear and Non-Linear Load

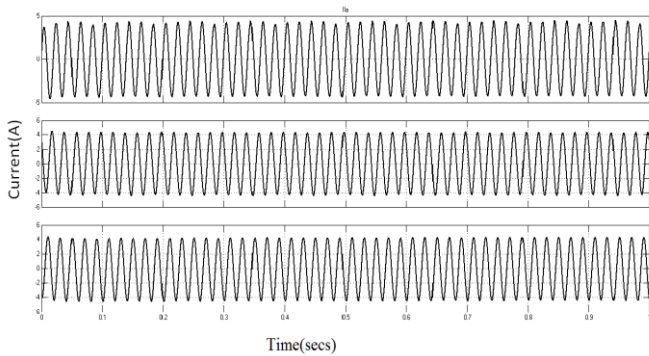

(e) Current at CPI with Linear Load

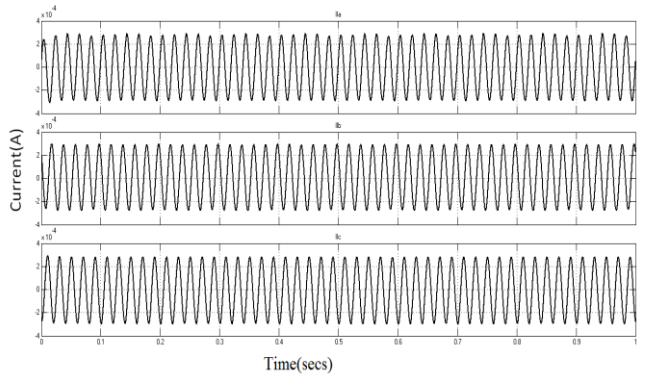

(f) Current at CPI with Non-Linear Load

Fig. 5 Output current and voltage of DG interfaced solar system with SOGI-Q control algorithm

The Fig.5 shows the output current and voltage of DG interfaced solar system with SOGI-Q control algorithm. Fig. 5(a) shows the output voltage from voltage source inverter. Figs. 5(b) & (c) show the distribution grid system voltage and current. The grid current are balanced (can be observed from magnitude) and sinusoidal. The VSC currents are so adjusted that the grid currents are balanced and sinusoidal. From the above figure, it is observed that with control algorithm the grid currents are balanced while without control algorithm the grid current is unbalanced. Figs. 5(d)-(f) shows the output voltage and current of linear and non-linear load. The power is being supplied by the grid and the power is absorbed by the load.

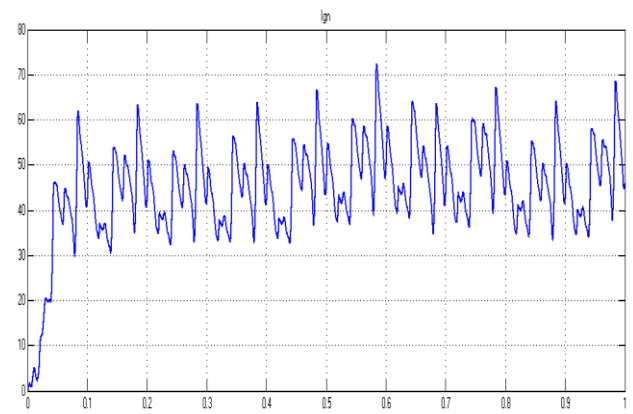

(a) Without Control Algorithm

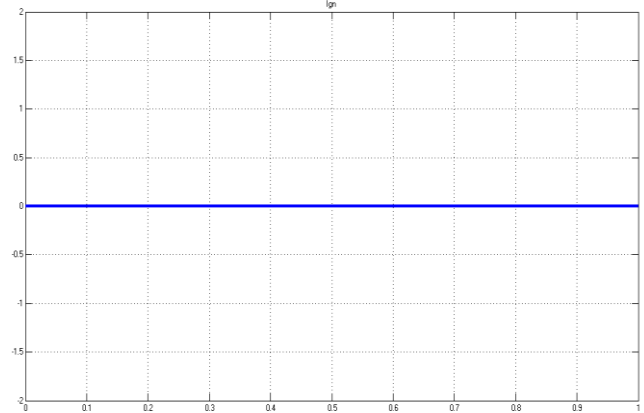

(b) With SOGI-Q Control Algorithm

Fig.6 Neutral Current of Distribution Grid System

Fig.6 shows the neutral current of distribution system without and with SOGI-Q control algorithm. With nonlinear loads at the CPI, all triplen harmonics and zero sequence currents flow through the neutral conductor. The neutral current increases losses in the distribution system. Neutral current in the grid can be mitigated by SOGI-Q control algorithm.

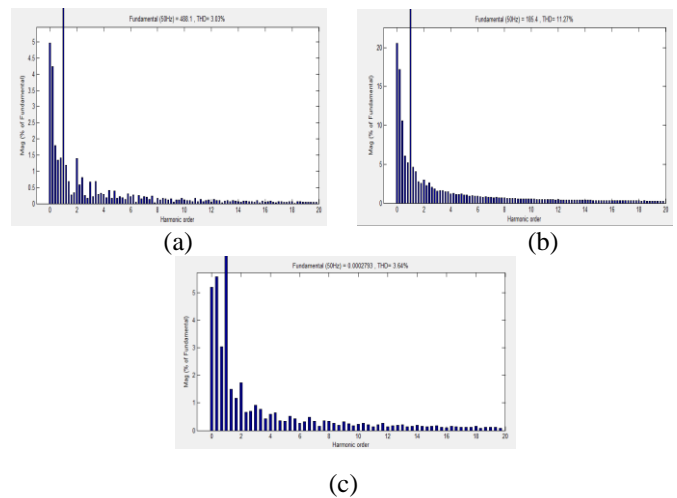

Fig. 7 THD of (a) Grid Voltage (b) Grid Current and (c) Load Current without control algorithm

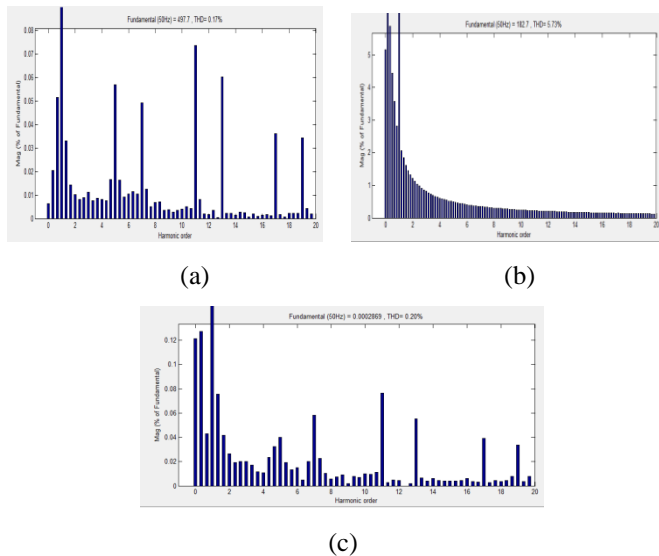

Fig. 8 THD of (a) Grid Voltage (b) Grid Current and (c) Load Current with SOGI-Q control algorithm

Fig.7 and 8 shows the FFT analysis of the DG system without and with SOGI-Q control algorithm. It is observed that, the THD of grid current is 5.73 % however that of load current is of order of 0.20%. The THD of VSC current is higher as compared to grid current as it consists of load current harmonics. From the performance analysis, with SOGI-Q control algorithm the THD value of grid current, grid voltage and load current is decreased when compared to the THD value without control algorithm.

IV. CONCLUSION

A two-stage grid tied multifunctional solar energy generation system has been proposed. Maximum power has been extracted from the solar PV by composite InC control algorithm. SOGI-Q based control algorithm has been proposed for the control of multifunctional four-leg VSC. The proposed system not only feeds the available solar energy into the grid but also helps in power quality improvement at CPI. Neutral current of the distributed grid system is mitigated by SOGI-Q control algorithm. A PVFF term has improved the dynamic response for CPI voltage variation. The performance of SOGI-Q control algorithm is validated through the simulation results.

REFERENCES

[1] Eltawil MA, Zhao Z. "Grid-connected photovoltaic power systems: technical and potential problems—A review" *Renewable and Sustainable Energy Reviews* 2010; 14:112–29.

[2] Y. M. Chen, A. Q. Huang, and Y. Xunwei, "A high step-up three-port dc/dc converter for stand-alone pv/battery power systems," *IEEE Trans. Power Electron.*, vol. 28, no. 11, pp. 5049-5062, Nov. 2013.

[3] D. Debnath and K. Chatterjee, "Transformer coupled multi-input two stage stand alone solar photovoltaic scheme for rural areas," in *Proc. IEEE IECON*, pp. 7028-7033, Nov. 2013.

[4] Hohm D, Ropp M. "Comparative study of maximum power point tracking algorithms. *Progress in photovoltaics*" *Research and Applications* 2003;11: 47–62.

[5] A. F. Murtaza, H. A. Sher, M. Chiaberge, D. Boero, M. D. Giuseppe, and K.E. Addoweesh, "A novel hybrid MPPT technique for solar PV applications using perturb & observe and fractional open circuit voltage techniques," in *Proc. 15th Int. Symp. MECHATRONIKA*, 2012, pp. 1–8.

[6] M. A. Elgendy, B. Zahawi, and D. J. Atkinson, "Assessment of the incremental conductance maximum power point tracking algorithm," *IEEE Trans. Sustain. Energy*, vol. 4, no. 1, pp. 108–117, Jan. 2013.

[7] B. Singh and J. Solanki, "A comparison of control algorithms for DSTATCOM," *IEEE Trans. Ind. Electron.*, vol. 56, no. 7, pp. 2738–2745, Apr. 2009.

[8] B. Singh, S. K. Dube, S. R. Arya, A. Chandra, and K. Al-Haddad, "A comparative study of adaptive control algorithms in distribution static compensator," in *Proc. IEEE Annu. Conf. Industrial Electronics Society (IECON)*, 2013, pp. 145–150.

[9] P. Kumar and A. Mahajan, "Soft computing techniques for the control of an active power filter," *IEEE Trans. Power Delivery*, vol. 24, no. 1, pp. 452–461, Feb. 2009.

[10] B. Singh, A. Adya, A. P. Mittal, and J. R. P. Gupta, "Neural network based DSTATCOM controller for three-phase, three-wire system," in *Proc. Int. Conf. Power Electronics, Drives and Energy Systems*, 2006, pp. 1–6.

[11] A. Negi, S. Surendhar, S. R. Kumar, and P. Raja, "Assessment and comparison of different neutral current compensation techniques in three-phase four-wire distribution system," in *Proc. 3rd IEEE Int. Symp. Power Electronics for Distributed Generation Systems*, 2012, pp. 423–430.

[12] P. Jayaprakash, B. Singh, and D. P. Kothari, "IcosU algorithm based control of zig-zag transformer connected three phase four wire DSTATCOM," in *Proc. IEEE Int. Conf. Power Electronics, Drives and Energy Systems*, 2012, pp. 1–6.

[13] S. Deo, C. Jain and B. Singh "A PLL-Less Scheme for Single-Phase Grid Interfaced Load Compensating Solar PV Generation System" *IEEE Transactions on Industrial Informatics*, vol.11, no.3, pp.692-699, 2015.

[14] Bhim Singh, D.T. Shahani and Arun Kumar Verma, "Neural Network Controlled Grid Interfaced Solar Photovoltaic Power Generation," *IET Power Electronics* vol.7, no.3, pp. 614-626, July 2013.

[15] A. Kulkarni and V. John, "A novel design method for SOGI-PL for minimum settling time and low unit vector distortion," in *Proc. 39th IECON Industrial Electronics Society*, 2013, pp. 274–279.

[16] IEEE Recommended Practice and Requirements for Harmonic Control in Electric Power Systems 1992.