

# SUPERCAPACITORS ENERGY STORAGE BASED DSTATCOM MODELING AND SIMULATION FOR DISTRIBUTION SYSTEM

**Kuldeep SAHAY and Bharti DWIVEDI**

Department of Electrical Engineering,  
Institute of Engineering & Technology, Lucknow,  
Uttar Pradesh Technical University, Lucknow, UP -226021, India.

Tel.: 91-522-4048747, Fax: 91-522-2361631

E-mail: [ksahay.iitd@gmail.com](mailto:ksahay.iitd@gmail.com)

**Abstract:** - *There is an exponential increase in the number of non-linear loads in power distribution networks especially due to advances in power electronics technology. Loads such as variable speed drives, IT equipment; fluorescent lights, etc. form a major portion of non-linear loads. Domestic appliances such as TVs, computers, SMPS, UPS, etc. cause harmonic pollution which leads to increased harmonic distortion of current and voltages. Single-phase loads on a three-phase supply system result in an unbalance in the system voltage and supply current. Harmonic pollution resulting from these loads distributed in an unbalanced manner adversely affects proper functioning of utility equipments. Unbalance in the voltages affects the performance of other loads, mainly induction motors. DSTATCOM is a custom power device that is used to regulate the voltage sags/swells in the distribution system for maintaining the rated voltage level at the terminal of load/sensitive loads. The DSTATCOM can inject three-phase voltages at point of common coupling whose magnitude and phase angle can be regulated with PI controller, while the supercapacitors are used to meet the instantaneous power demand since they can store and quickly release significant amounts of energy. This paper explores the use of Supercapacitors in DSTATCOM in place of battery for control of load terminal voltage.*

**Keywords:** *Distribution Static Compensators (DSTATCOM), Power Conditioning System (PCS), Supercapacitors Energy Storage System (SCESS), Voltage Sags, Voltage Swells.*

## 1. Introduction

DSTATCOM are used for improvement of power quality in the distribution system. DSTATCOM, however, are limited in their ability to improve system performance due to limited capability of delivering quick/instantaneous real power. Conventionally in the DSTATCOM battery is used for energy storage purpose, though batteries have a high energy density but do not possess instantaneous charge and discharge capabilities and normalized voltage swing ( $U_{\min}/U_{\max}$ ) at open circuit for batteries is higher than 0.85. Therefore it cannot handle transient state problems efficiently.

From the last decade, there have been considerable developments and improvements in energy storage technologies for example, SMES, Flywheel, Fuel Cells and also in the battery technologies. On the contrary, these technologies have some limitations,

SMES require a lot of space, high shielding for its magnetic effect and complex auxiliary system, fuel cells quite slow initial response and batteries life deteriorates very fast in case of full discharge and limited number of charge/discharge cycle [1,2,3].

The recent development of Supercapacitors has given a hope in the field of energy storage technologies, which can store a very large amount of energy and it have very fast instantaneous power/energy charge and discharge capabilities in the regulated manner with the help of custom power devices, independent of number of charge and discharge cycle, voltage swing is 0.5 and is limited by the power conditioning system which do not allow the supercapacitors depth of discharge to go above 75% ,very high efficiency, life about 20-25 years and charge and discharge times are fractions of a second to several minutes [4]. The energy stored in the SCESS is used to provide

real power and reactive power through the inverter to the distribution network. Therefore the DSTATCOM based on SCESS would inject an appropriate voltage magnitude with appropriate phase angle in shunt to the distribution system, when the voltage sag occurs; the voltage injection is achieved through the injection of real and reactive power.

The aim of this research is to investigate the use of the supercapacitors energy storage based DSTATCOM to enhance power quality of distribution system by means of precise & fast regulation of voltage sags/swells and control of SCESS voltage level by simulating in MATLAB/SIMULINK POWER.

## 2. Design of Supercapacitors Energy Storage System

The purpose of connecting the SCESS in DSTATCOM for smoothing the power fluctuation via charging and discharging the real power which may be due to peak demand, transient fault and other reasons. Another application is voltage management across the load terminal. The supercapacitors voltage  $U_{sc}$  will drop to 0 V if all the stored energy is utilized then the constraint rated power output capability would be violated i.e.  $P_{stored} \times P_{rated}$ . Therefore a lower limit is fixed on the supercapacitors voltage  $U_{min}$ , is 50 % of  $U_{max}$ , so that 75 % of stored energy can be utilized efficiently. Since the voltage of supercapacitors cell is low therefore the supercapacitors bank would consist of number of supercapacitors cells in series and parallel so that the required voltage level and sufficient useful energy can be stored. The schematic diagram is shown in the Fig.1.

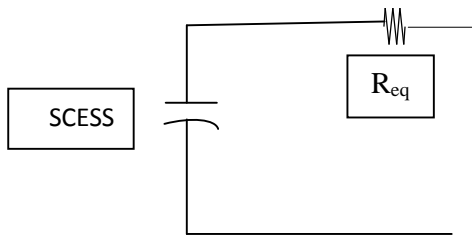

Fig. 1 Supercapacitors Module.

In general, the number of series connected cells  $N_s$  in one branch are imposed by the rating of

supercapacitors cells maximum voltage available in the market or in the stack.

$$N_s = U_{max}/U_{cell} \quad (1)$$

Where

$N_s$  are number of cell connected in series.

$U_{max}$  is maximum voltage of the supercapacitors bank.

$U_{cell}$  is rating of supercapacitors cell.

The number of parallel branch  $N_p$  in the supercapacitors bank can be found by

$$N_p = N_s C_{eq}/C_{cell} \quad (2)$$

To have sufficient energy storage capacity number of parallel branches must be more than or equal to the one ( $N_p \times 1$ ) and rounded upward side to nearest integer.

The equivalent capacitance of the supercapacitors bank is represented by the following formula

$$C_{eq} = (N_p \times C_{cell})/N_s \quad (3)$$

Where

$C_{eq}$  is equivalent capacitance of supercapacitors bank in Farad.

$C_{cell}$  is capacitance of each cell in Farad.

$N_s$  are number of cell connected in series.

$N_p$  is number of parallel arms in supercapacitors bank.

From equation (3) it is clear that to have net higher equivalent capacitance of the bank, number of the parallel arms ( $N_p$ ) should be always higher than  $N_s$ , in that way higher energy storage capacity.

Total numbers of cell in Supercapacitors bank would be

$$N_T = N_s \times N_p \quad (4)$$

Where

$N_T$  is total number of cells required in supercapacitors bank.

But when the supercapacitors works at minimum voltage point, rated power output capability is still required, so

$$N_T \times U_{min}^2 / 4R_{eq} \geq P_{scess} \quad (5)$$

$U_{min}$  limitation under power request is expressed as

$$U_{min} \geq 2\{\sqrt{(R_{eq} P_{scess} / N_T)}\} \quad (6)$$

The appropriately designed SCESS should consider both the power demand and energy capacity and the overall efficiency of SCESS, therefore the useful energy stored in the SCESS is expressed by (7) while keeping the voltage constraints  $U_{min} < U < U_{max}$

$$E_u = \eta_s C_{eq} (U_{max} - U_{min})^2 / 2 \quad (7)$$

Where

$\eta_s$  efficiency of supercapacitor bank.

The proposed supercapacitors energy storage system is designed to have storage of 1 MWh (3600 MJ) of energy, 440 V voltage and peak power of 1000 kW connected to distribution system to supply the load in case of voltage variation and additional power demand. The supercapacitors used are of Nesscap Co. Ltd. Korea make having product specifications, Nominal capacitance 51 F, Rated voltage 340 V, Surge voltage 367.2 V, VESR <19 m, Operating temperature range -40°C to +65°C, Specific Energy 2.13 Wh/kg, Cycles 500,000(at 25 °C), Lifespan 10 years, Maximum peak current(1 sec) 3,854 A. Then the SCESS designed would be as following:

Table I  
SCESS Configuration

Item	Symbol	Value
Maximum supercapacitors Voltage	$U_{max}$	623 V
Minimum supercapacitors Voltage	$U_{min}$	312 V
Equivalent capacitance of SCESS	$C_{eq}$	13912.9 F
Number of units connected in	$N_s$	2

series		
Number of parallel arms in SCESS	$N_p$	545
Total number of units required in supercapacitors bank	$N_T$	1090
Equivalent series resistance of SCESS	$R_{eq}$	66 $\mu$
Discharge voltage ratio	d	50%

### 3. Simulink modeling of the DSTATCOM and its Control

A DSTATCOM which consists of a two level voltage source converter as inverter, supercapacitors bank as energy storage device, a coupling transformer connected in shunt to the distribution network. The voltage source converter converts the dc voltage of the supercapacitors bank into sets of three phase ac voltages as output. These voltages are in phase and coupled with the distribution system through reactance of the coupling transformer. The proper adjustment of the phase and magnitude of the DSTATCOM output voltages allows effective control of the active and reactive power exchanges between the D-STATCOM and the distribution network[6,7].

The VSC connected in shunt with the distribution network can be used for voltage regulation and compensation of reactive power, power factor correction and elimination of harmonics. The continuous voltage regulation of the distribution network is performed by injecting the shunt current for elimination of the voltage sag across the system impedance. The value of current can be controlled by adjusting the output voltage of the converter. The efficacy of the DSTATCOM in correcting voltage sag depends on the value of equivalent thevenin impedance of the system or the fault level of the load bus. When the shunt injected current is in quadrature with the load terminal voltage, the desired voltage correction can be achieved without injection of the active power into the distribution network. On the other hand, when the value of shunt current is minimized, the same voltage correction can be achieved with minimum apparent power injection into the system.

The control scheme for the DSTATCOM is shown in the Fig. 2. The controller input is an error signal obtained from the DC reference voltage and the measured terminal voltage of the SCESS. Such error is processed by a discrete PI controller and the output is  $I_{d\_ref}$ , which is provided to current regulator. The current regulator output is passed to sinusoidal

voltage error generator; this error signal is provided to discrete PWM signal generator. The PWM generator, generates the pulse signals that are passed to voltage source converter to generate the output voltage as per load requirement on the point of common coupling.

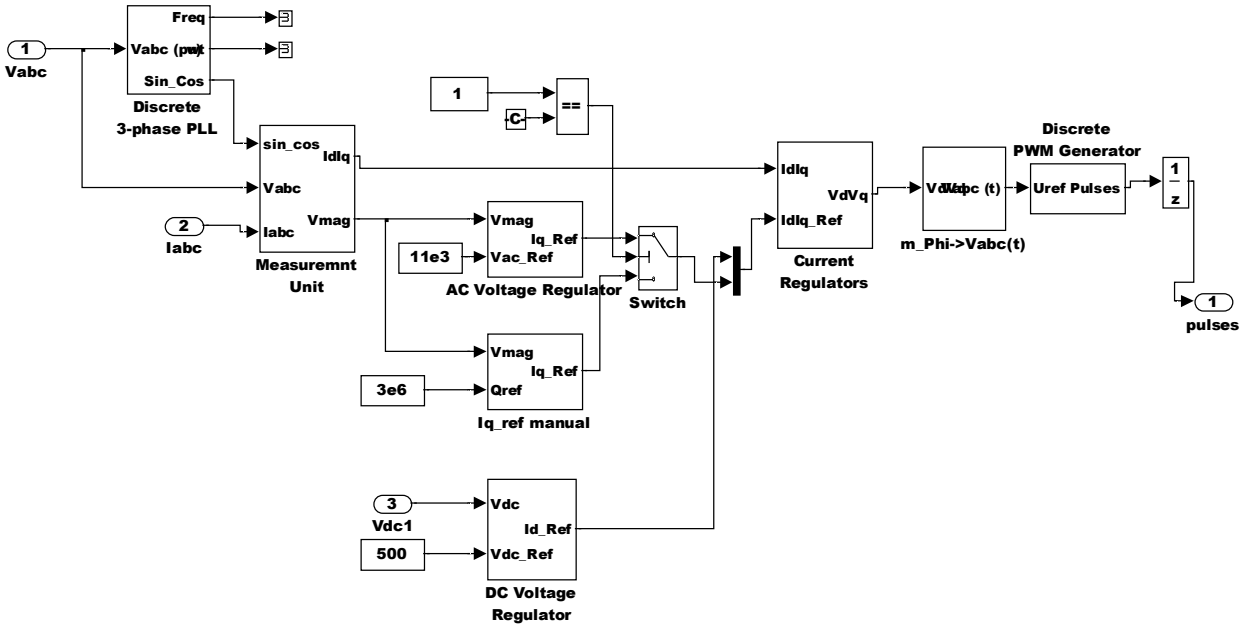

Fig. 2 Control Scheme of DSTATCOM

Fig. 3 shows the test system used to carry out the various DSTATCOM simulations in MATLAB/SimPower SIMULINK. The test system comprises of a 11 kV, 50 Hz transmission system-section of 25 km long and T-section of 2 km long, feeding into the primary side of 2-winding transformer connected in Y/Δ, 11 kV/440 V, 100 MVA. The load is connected to 440 V, secondary side of the transformer.

The DC voltage is applied to IGBT/Diode of two-level inverter generating 50 Hz. The IGBT of the inverter uses pulse width modulation at 1680 Hz carrier frequency, discretized sample time of  $5.8e^{-6}$  sec. The load voltage is regulated at 1 pu by PI voltage regulators of dc regulator, the input of DC

regulator are voltage of PCC, current of PCC, SCESS voltage and the output is a vector containing the three modulating signals used by the discrete pulse width modulation generator to generate the 6 IGBT pulses. The harmonics generated by the inverter are filtered by LC filter. The three coupling transformer of 440 V/11 kV, 100 MVA are used to connect the DSTATCOM to the distribution network. A SCESS of 13912.9 F are connected on the dc side to provide the energy/real power. The effectiveness of this arrangement in voltage regulation can be seen on simulating the test system with and without DSTATCOM/SCESS.

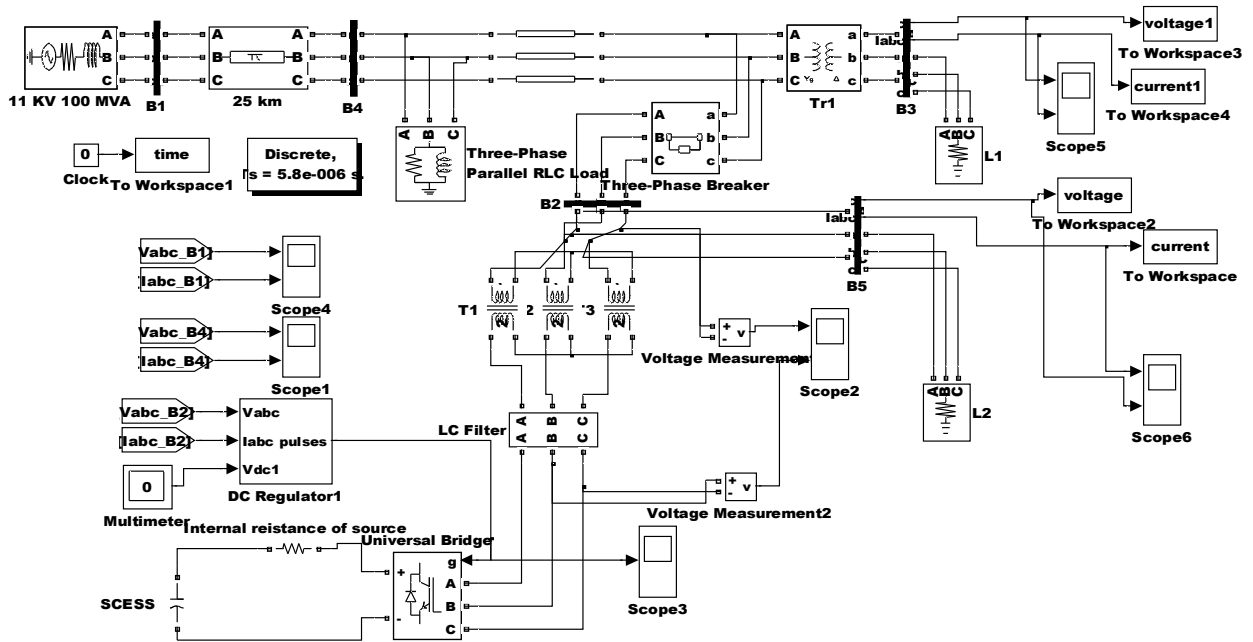

Fig.3 Developed Test System for DSTATCOM

#### 4. Simulation and Result Analysis

##### Case:-1 Simulation Results when Supercapacitors are not charged

The first simulation was performed when the DSTATCOM's supercapacitors were not charged and

the main supply to load is switched off by the three phase circuit breaker for period of 0.2-0.3 second ,during this period the voltage across the load approaches to zero and current through the load also becomes zero as shown in the Fig.4 and Fig.5.

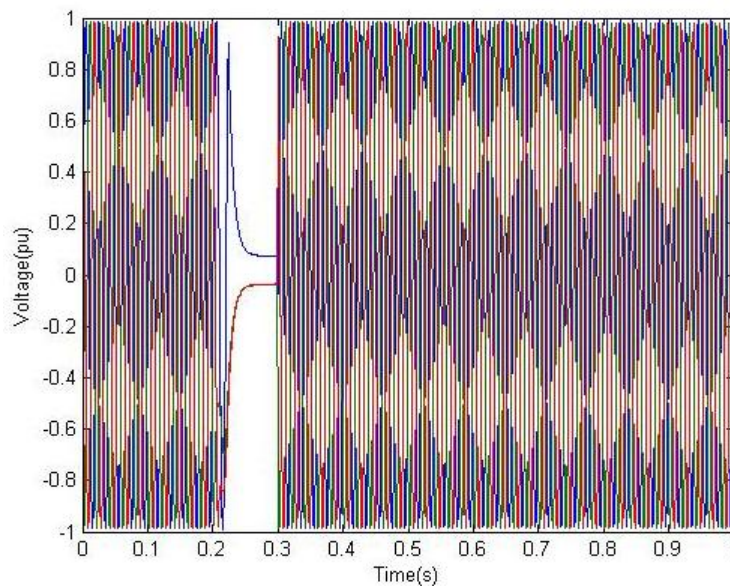
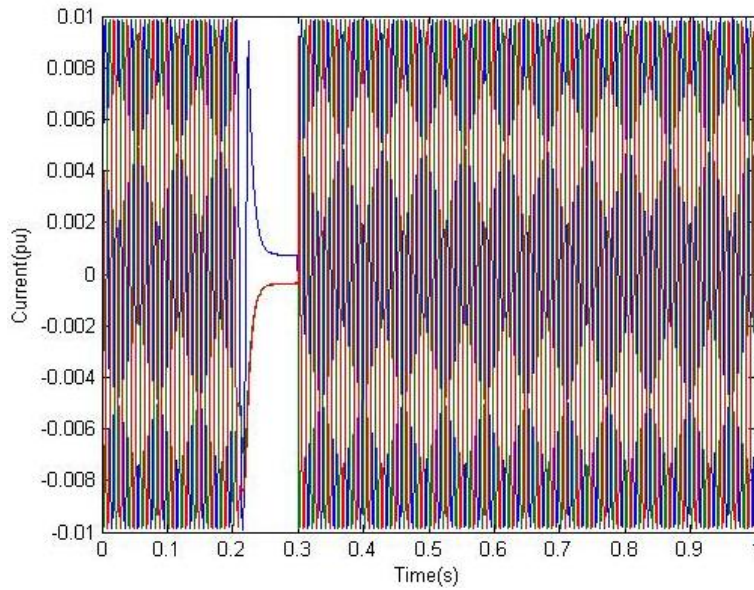

Fig.4 Voltage across the load when supercapacitors are not charged.

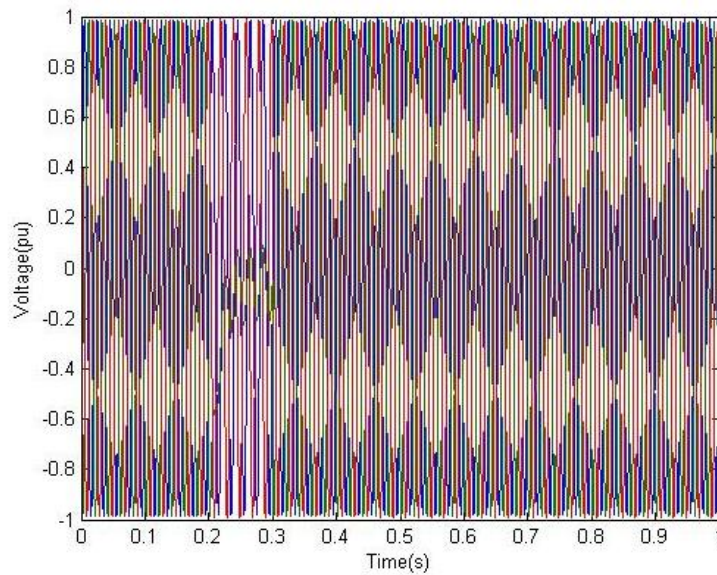

**Fig.5 Current through the load when supercapacitors are not charged**

**Case:-2 Simulation Results when supercapacitors are charged below  $U_{min}$ .**

Similarly, a new set of simulations was carried out but the now the DSTATCOM supercapacitors had discharged below the  $U_{min}$  level, while the three-phase circuit breaker for duration 0.2-0.3 sec in which main line supply was cutoff, but now the voltage across the load in phases is able to

maintain but for the third phase the DSTATCOM was not able to supply the power properly as required. The voltage and current waveforms are shown respectively in Fig.6 and Fig.7.



**Fig.6 Voltage across the load when supercapacitors are charged below  $U_{min}$ .**

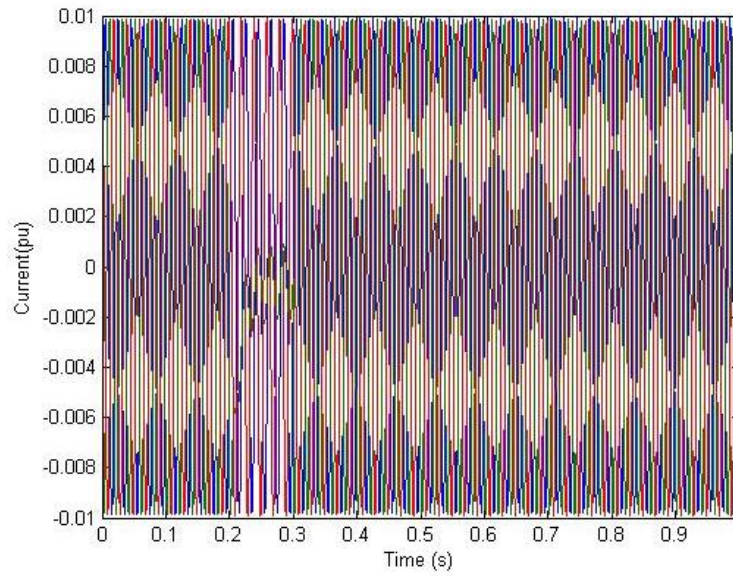
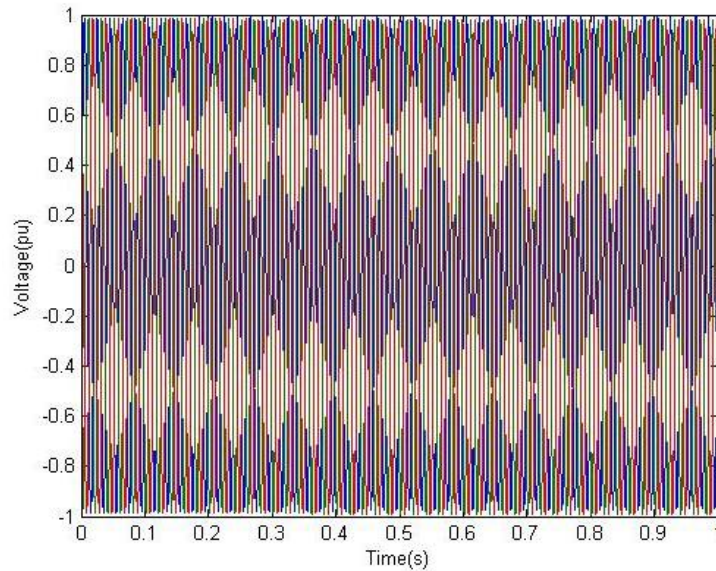

**Fig.7 Current through the load when supercapacitors are charged below  $U_{min}$**

**Case: 3 Simulation Results when supercapacitors are charged properly**

Similarly, a new set of simulations was carried out but the now in the DSTATCOM the supercapacitors are charged properly, a transient load was switched in test system for the duration 0.2-0.3 sec in which

main line supply was also cutoff with the help of three phase circuit breaker. The Supercapacitors based DSTATCOM is quit efficient to support the load without any unbalance in phase and having no harmonics also able to maintain its amplitude of 1.0 pu. The voltage and current waveforms are shown respectively in Fig.8 and Fig.9.



**Fig.8 Voltage across the load when the supercapacitors are charged properly**

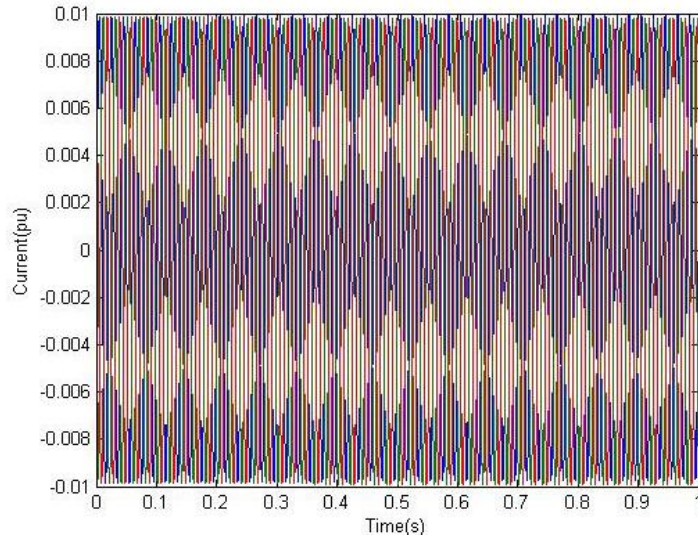

**Fig.9 Current through the load when the supercapacitors are charged properly**

## 5. Conclusions

Supercapacitors energy storage has been used as a storage device in place of battery of a DSTATCOM device. This allows the DSTATCOM to deliver the real power into grid for short periods of the time. The highly developed graphic facilities available in MATLAB/SIM-Power Simulink were used to conduct all aspects of model implementation and to carry out extensive simulation studies on developed test systems. A PWM based control scheme has been implemented to control the switches (IGBT/Diode) in the two level voltage source converters which controls the supercapacitors to deliver/absorb the real power as per the requirement and also maintains the loads power factor unity. This characteristic make it suitable for custom power applications where very sensitive loads are connected, since performance of the control scheme has been studied with sudden disruption of the main supply and switching in a bulk load into the test system and found able to mitigate the voltage sag and at the same time maintaining the load power factor unity.

## References:-

1. Srithorn, P. Sumner, M. Liangzhong Yao Parashar, R., "Power System Stabilisation Using STATCOM with Supercapacitors", *Industry Applications Society Annual Meeting, 2008. IAS '08. IEEE*, Edmonton, Alta, Dated: 5-9Oct.2008, page(s):1-8.
2. Srithorn, P. Sumner, M. Liangzhong Yao Parashar, R., "The Control of a Statcom with supercapacitor energy storage for improved power quality" *Smart Grids for Distribution, 2008. IET-CIRED Seminar, Frankfurt, Dated: 23-24 June 2008*, page(s): 1-4.
3. Nasiraghdam,H., and Jalilian A. "Balanced and Unbalanced voltage sag Mitigation Using Dstatcom with Linear and Nonlinear loads" *International Journal of Electrical, Computer and Systems Engineering* 1;2© www.waset.org.Spring 2007,Page(s) 86-91.
4. Zhai, N.S. Yao, Y.Y. Zhang, D.L. Xu, D.G., "Design and Optimization for a Supercapacitor Application System", *International Conference on Power System Technology, PowerCon 2006, Chongqing, Dated 22-26 Oct. 2006*, page(s): 1-4.
5. Xiao Li Changsheng Hu Changjin Liu Dehong Xu, "Modeling and control of aggregated Super-Capacitor Energy Storage system for wind power generation", *Industrial Electronics, 2008. IECON 2008. 34th Annual Conference of IEEE, Dated: 10-13 Nov. 2008, Orlando, FL*, page(s): 3370-3375.
6. Ravi Kumar, S.V. and S.Siva Nagaraju "Power Quality Improvement using D-Statcom and DVR" *International Journal of Electrical and Power Engineering* 1(3):368-376, 2007, Medwell Online Journals.
7. Van Voorden, A.M. Elizondo, L.M.R. Paap, G.C. Verboomen, J. Van der Sluis, L., "The Application of Super Capacitors to relieve Battery-storage systems in Autonomous Renewable Energy Systems", *Power Tech, 2007 IEEE Lausanne, Date: 1-5 July 2007*, page (s): 479-484.