

COMPARISON PERFORMANCES BETWEEN TWO MATRIX CONVERTERS [3X3] AND [3X5] SUPPLYING A MULTI-PHASES INDUCTION MACHINE

M. M. REZAOUI A. KOUZOU

LAADI, Faculty of Science and Technology, University of Djelfa 17000 DZ, Algeria
mm_rezaoui@yahoo.fr

M. O. MAHMOUDI L. NEZLI

LCP, Ecole Nationale Polytechnique, 10 av. Pasteur, Hassen Badi, 16200, El Harrach, Algiers, Algeria

Abstract: The aim of this paper is to replace the traditional three phases systems (machine-converter) by other multi-phases systems, for that a detailed comparison between two systems controlled with Field Oriented Control of induction machine three and five phases fed a [3x3] and [3x5] matrix converters respectively are proposed, emphasizing advantages and disadvantages if they exist.

The performance of the two systems is evaluated in terms of output voltages by simulation and by implementation in real time (dSpace 1103) their THDs, torque ripples rate, input/output currents sine waveform, and rapid response of speed curves. The analysis has been carried out on the basis of results obtained by numerical simulations using Matlab/Simulink for the validation of the proposed control strategy and to clarify the main related advantages

Key words: Matrix converter, induction machine, multi-phases, Field Oriented Control.

1. Nomenclature

V_R, V_S, V_T	Input Voltages of matrix converter
V_A, V_B, V_C, V_D, V_E	Matrix converter output voltages
f_i, f_o	Input/ Output frequency
i_s, i_r	Stator and rotor currents
$i_{ds}, i_{qs}, i_{dr}, i_{qr}$	Stator and rotor currents d-q axis components
$V_{ds}, V_{qs}, V_{dr}, V_{qr}$	Stator and rotor voltages d-q axis components
ϕ_d, ϕ_q	Stator flux d- q axis components
R_r, R_s	Stator- Rotor resistance
L_d, L_q	d- q magnetizing inductance
L_s, L_r	Stator/ Rotor inductance
L_m	Mutual inductance
T_{em}	Electromagnetic torque
T_r	Load torque
J	Total inertia
p	Number of pole pairs
ω_i, ω_o	Input/ Output pulse
Ω	Rotating speed

k	1, 2 and 3 in three phase 1, 2, 3, 4 and 5 in five phase
---	---

2. Introduction

Recently, multi-phases system drives have been received more attractive attention due to their potential value in high power drives compared with their counterparts of traditional three phases system drives [1], [2]. It was proved that the multi-phases machines have some advantages such as; an increased torque pulsation frequency, an increased stator current per phase, an improved torque per ampere, an improved power density of the electric machine [1]. On the other side, the space-harmonic in a multi-phases machine is less than three phases machine, whereas the redundancy in a multi-phases machine is greater than in three phases. Indeed it presents a better fault tolerance when one or more phases are lost [3-6]. Actually, the applications of multi-phases induction motor drives is attracting more attention in the field of high power systems with great reliability such as marine propulsion, railway traction, electrical vehicles and aerospace applications [1-3], [6].

The intensive research on Matrix Converters (MCs) was started with the first appeared work of Venturini and Alesina in 1980 [7]. They presented the mathematical model background and introduced the name of “matrix converter”. One among the important difficulties which have been face in the operation of this converter was the commutation of the bidirectional switches [8]. However, this problem has been solved by introducing intelligent and soft commutation techniques.

The matrix converter is recently being a popular converter topology which has been actively studied due to many desirable features that can be met for ensuring power conversion under high flexibility [9-11]. It allows to generate variable magnitude and variable frequency of the output voltage from an AC utility grid input without the need of DC link capacitor storage

element at the input side [12-16]. It has sinusoidal input/output currents with nearly unity power factor and fully regeneration capability [17-19]. Unfortunately, there is a major limitation of the maximum available output voltage of the matrix converter up to 86.6 % of the input voltage within the linear modulation range [16]. The matrix converters can generally be classified into two main types: direct matrix converters (DMCs) and indirect matrix converters (IMCs). The direct matrix converters utilize only the bidirectional, bipolar (four-quadrant) switches [2] based on a direct AC-AC power conversion by connecting three-phase input voltages to three-phase output loads without bulky capacitor [1]. Whereas, the indirect matrix converters utilize four-quadrant switches, these kind of converter are based on the same idea of classical converter AC-DC-AC (rectifier stage and inverter stage) topology. It is obvious that the classical converter AC-DC-AC with the intermediate capacitor, which has been used for feeding the multi-phases system drives, has some disadvantages such as distorted input current and poor input power factor [10].

In the past two decades and due to the increased need for the improvement of the power quality and the efficiency of the power supply side and the usage side, the matrix converters (MCs) has been proposed to become a major modern energy converter that can overcome some drawbacks of other converters. The main advantages of the MCs are presented as follows [11], [20-25]:

- The Elimination of the bulky DC link capacitor,
- the straight forward Four-quadrant operation, which allows an appropriate switching devices control,
- The output voltage and input current contain only harmonics around or above switching frequency with reduced magnitudes,
- The output frequency is theoretically almost unlimited. The only limit of the output frequency is due to the maximum switching frequency constraint of the power switches.
- The ease possibility use of the direct AC-AC multi-phases power conversion,
- The inherent bidirectional power flow capability,
- A compact power circuit because of the elimination of bulky reactive elements.
- A longer lifespan due to the absence of capacitor [26].

For that, one of the integral inventions in the AC motor

drives was commonly used field-oriented control or vector control, which widened the opportunities for the upcoming researches in order to enhance the control performance through the research and development programs [27].

In this paper, the models of three phases and five phases induction machine are presented, then followed by the study of the two kinds of matrix converters; the first one is the [3x3] matrix converter under the control strategy of PMW three intervals [32-36]. The second is the [3x5] matrix converter under the control strategy of the proposed modified PMW three intervals. These two machines are controlled by Field Oriented Control (FOC) applied to a three and five asynchronous machine; the technique of the FOC or vector control based on the rotor field orientation applied to the induction motor provides the decoupling between the torque and flux in a similar way to the DC machine [28-31]. Finally, a comparative study between two kinds of matrix converter, the [3x3] matrix converter feeding three-phase induction machines and the [3x5] matrix converter feeding five-phases induction machines using the Field Oriented Control method to show the advantages based on the performance response and the THD of the both topologies respectively. This study will enable us to identify the merits of each of them in order to make a judicious choice for their use in matrix converter control applications.

3. Model of the induction motor

The three-phases induction motor can be presented by the equations of the stator and rotor voltages as follows:

$$[V_s] = [I_s][R_s] + \frac{d[\phi_s]}{dt} \quad (1)$$

$$[V_r] = [I_r][R_r] + \frac{d[\phi_r]}{dt} \quad (2)$$

The electromagnetic torque is expressed as follows:

$$C_{em} = (p/2) \left\{ [I_s]^T \frac{d[L_{s,r}]}{d\theta} [I_r] \right\} \quad (3)$$

To obtain a simple mathematical model similar to the physical model of the system, the Park transformation is used to transform a three-phases system (a, b, c) in a two-phases equivalent system (d, q). The matrix of transformation is defined as follows [33-34]:

$$P(\theta) = \sqrt{\frac{2}{3}} \begin{bmatrix} \cos(\theta) & \cos(\theta - 2\pi/3) & \cos(\theta + 2\pi/3) \\ -\sin(\theta) & -\sin(\theta - 2\pi/3) & -\sin(\theta + 2\pi/3) \end{bmatrix} \quad (4)$$

Whereas, the transformation matrix for a five-phase system to two-phase system is expressed as follows [37-38]:

$$P(\theta) = \sqrt{\frac{2}{5}} \begin{bmatrix} \cos(\theta) & \cos(\theta - \frac{2\pi}{5}) & \cos(\theta - \frac{4\pi}{5}) & \cos(\theta - \frac{6\pi}{5}) & \cos(\theta - \frac{8\pi}{5}) \\ -\sin(\theta) & -\sin(\theta - \frac{2\pi}{5}) & -\sin(\theta - \frac{4\pi}{5}) & -\sin(\theta - \frac{6\pi}{5}) & -\sin(\theta - \frac{8\pi}{5}) \end{bmatrix} \quad (5)$$

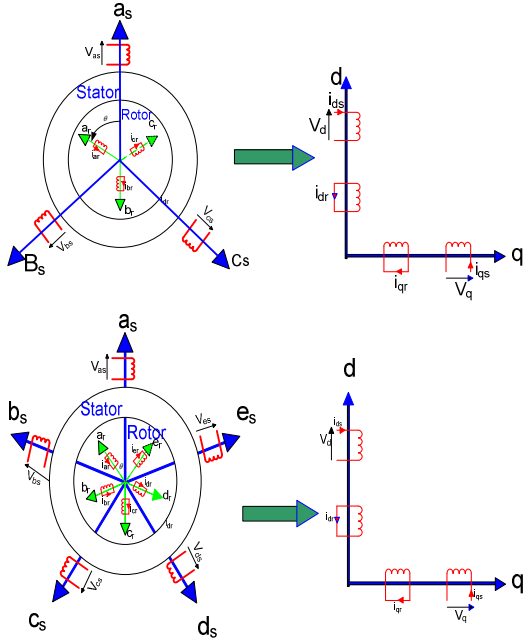

Fig. 1. The modeling of three and five phases machine in the coordinate d-q.

By the application of Park transformation, to the systems presented in (1) and (2). The representation of the new systems in d-q frame under a reference frame related to the rotating field is obtained [32-33]:

$$\begin{cases} V_{ds} = R_s I_{ds} + \frac{d\phi_{ds}}{dt} - \omega_s \phi_{qs} \\ V_{qs} = R_s I_{qs} + \frac{d\phi_{qs}}{dt} + \omega_s \phi_{ds} \\ 0 = R_r I_{dr} + \frac{d\phi_{dr}}{dt} - (\omega_s - \omega_r) \phi_{qr} \\ 0 = R_r I_{qr} + \frac{d\phi_{qr}}{dt} + (\omega_s - \omega_r) \phi_{dr} \end{cases} \quad (6)$$

Where:

$$\begin{cases} \phi_{ds} = L_s I_{ds} + L_m I_{dr} \\ \phi_{qs} = L_s I_{qs} + L_m I_{qr} \\ \phi_{dr} = L_r I_{dr} + L_m I_{ds} \\ \phi_{qr} = L_r I_{qr} + L_m I_{qs} \end{cases} \quad (7)$$

The mechanical equation representing the dynamic

model of the electromechanical torque and the mechanical motion provided by the machine are expressed in the following equations:

$$\begin{cases} T_{em} = \frac{L_m P}{L_r} (\phi_{dr} I_{qs} - \phi_{qr} I_{ds}) \\ T_{em} - T_r = J \frac{d\Omega_r}{dt} \end{cases} \quad (8)$$

4. The [3x3] matrix converter

The matrix converter is a static frequency and voltage converter which can fulfill the main characteristic of conventional DC/AC back to back converters (rectifier - inverter). Furthermore the matrix converter allows obtaining an output multi-phases voltage with variable amplitude and frequency from an input multi-phases voltages power supply [39]. The topology of the [3x3] MC is shown in Fig.2; it is characterized by a matrix of nine switches [3x3]. This MC ensures the conversion of the three phases power supply to three-phase output voltage using bidirectional power switches. Each switch can be modeled by two diodes and two transistors where the main aim is to reduce the number of possible configurations of the matrix converter [39].

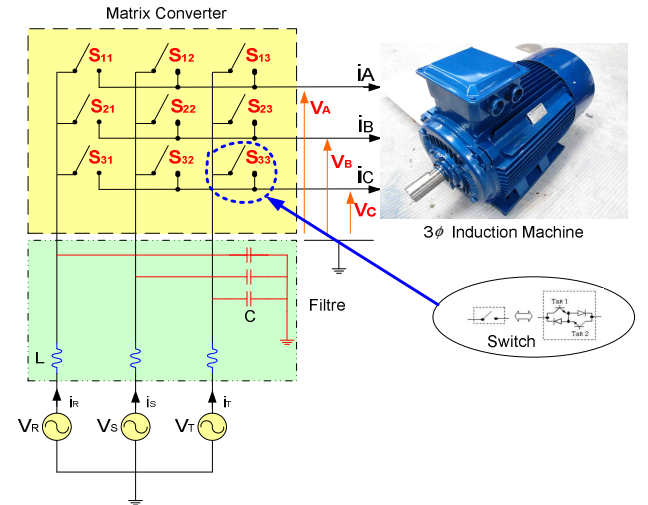

Fig. 2. Schematic diagram referred to the [3x3] MC.

Since the MC is an idealized coupling, the principle of causality leads to precise rules concerning the different states of the switches, therefore [1-3] [34];

- Sources that are connected on both sides of the MC are necessarily different in nature.
- At least one switch of the three switches connected to one phase should be closed to avoid the open circuit effect;
- Only one switch of the same leg should be closed to avoid the short-circuit of the input power supply;

It is obvious that under these conditions, the total possible switching states configuration is reduced to 3^3 . On the other side, the commutation function of each leg presents a symmetrical function, and consequently a symmetrical control of each leg should be met, Fig.4 [35-36].

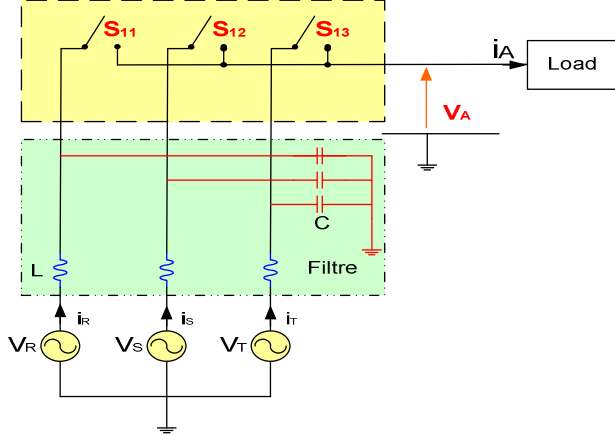

Fig. 3. The cellular commutation of matrix converter

In table. 1, the commutation for one output phase has 3 possible configurations.

Table.1. MC configuration of one output phase.

Configuration	The value of the output voltage "Phase A" related to the input voltages
E1	$V_A = V_R$
E2	$V_A = V_S$
E3	$V_A = V_T$

The principle of this strategy is to control the matrix converter based on the indirect converter which is analog to the conversion stages of (rectifier / inverter) [32]. To avoid the complexity of the matrix converter control, and to benefit from the merits of the conventional converter a fictitious intermediate voltage is introduced, hence the MC can be studied based on two separated virtual stages reflecting the two stages of the conventional converter (rectifier - inverter). Based on the fact that at any given time, there is at least one phase of the power supply voltage is positive and at least another phase is negative Fig. 4. The fictitious intermediate voltage can be chosen as follows:

$$U_d = U^+ - U^- \quad (9)$$

Where:

U_d : Intermediate virtual voltage.
 U^+ : The virtual positive potential.
 U^- : The virtual negative potential.

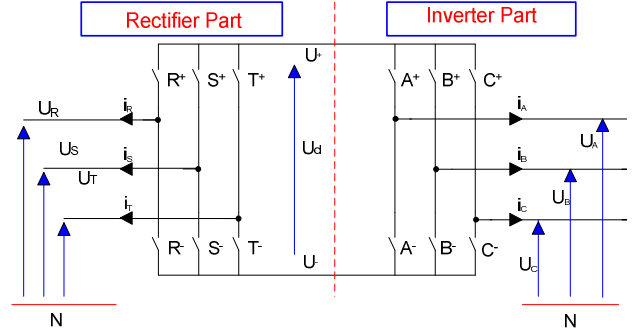

Fig. 4. Model of the MC with middle fictitious circuit

4. 1. Study of the rectifier stage

The harmonic spectrum study of the input current for this stage is very important. So it is necessary to use a modulation function to achieve an input current waveform nearly sinusoidal, while maintaining the same power to be transmitted via the intermediate circuit. This modulation function τ is defined as follows: [1] [32-33]

$$\tau = \frac{\cos(\Phi - 2\pi/3)}{\cos(\Phi)} + 1 \quad (0 \leq \tau \leq 1) \quad (10)$$

Where: $\Phi = (\omega t)_{\text{mod}(\pi/3)} - (\pi/6)$

The connection between the input voltages and the virtual potential are represented as follows [19]:

$$\begin{bmatrix} U^+ \\ U^- \end{bmatrix} = \begin{bmatrix} R^+ & S^+ & T^+ \\ R^- & S^- & T^- \end{bmatrix} \begin{bmatrix} V_{in1} \\ V_{in2} \\ V_{in3} \end{bmatrix} \quad (11)$$

$$\begin{cases} V_{in1} = V_R + V_0 \\ V_{in2} = V_S + V_0 \\ V_{in3} = V_T + V_0 \end{cases} \quad (12)$$

Where the expression of voltage V_0 is expressed as follows:

$$V_0 = -\frac{\text{Max}(V_{in1, 2 \text{ and } 3_ref}) + \text{Min}(V_{in1, 2 \text{ and } 3_ref})}{2} \quad (13)$$

$$\begin{cases} V_R = 220\sqrt{2} \sin(\omega_i t) \\ V_S = 220\sqrt{2} \sin(\omega_i t - 2\pi/3) \\ V_T = 220\sqrt{2} \sin(\omega_i t - 4\pi/3) \end{cases} \quad (14)$$

This technique allows the matrix converter to eliminate the third harmonics by injecting third harmonic voltage in the input voltage. The value of the virtual DC-voltage U_d will be varying as function of the line phase angle and the rectifier control functions. For example, in the interval $\pi/3 < \omega t < 2\pi/3$, the switches can take the values ($R^+ = 1, S^+ = 0, T^+ = 0$) and ($R^- = 0, S^- = 1 - \tau, T^- = \tau$).

The potential:

$$\begin{cases} U^+ = R^+ * V_R + S^+ * V_S + T^+ * V_T \\ U^- = R^- * V_R + S^- * V_S + T^- * V_T \end{cases}$$

Considering the symmetry during a recovery period, six intervals can be determined as it is shown clearly in Fig. 5.

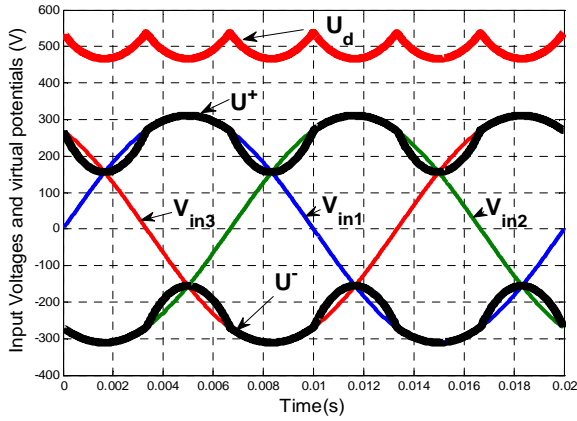

Fig. 5. Curve of the input voltages and virtual potentials

4.2. Study of the inverter stage

The modulation functions u_{cmk} will be introduced to define the modulation matrix $[M_r(t)]$, where U_{cmk} takes continuous values between 0 and 1. This allows a link between the middle potential and the output voltages of the matrix converter following to the below expression:

$$\begin{bmatrix} V_R \\ V_S \\ V_T \end{bmatrix} = \underbrace{\begin{bmatrix} U_{cm1} & 1-U_{cm1} \\ U_{cm2} & 1-U_{cm2} \\ U_{cm3} & 1-U_{cm3} \end{bmatrix}}_{[M_r(t)]} \begin{bmatrix} U^+ \\ U^- \end{bmatrix} \quad (15)$$

Taking into account the two blocks rectifier - inverter, the matrix $[M(t)]$ allows defining the complete algorithm function of frequency conversion. It can be presented as follows:

$$\begin{bmatrix} V_A \\ V_B \\ V_C \end{bmatrix} = \underbrace{\begin{bmatrix} U_{cm1} & 1-U_{cm1} \\ U_{cm2} & 1-U_{cm2} \\ U_{cm3} & 1-U_{cm3} \end{bmatrix}}_{[M(t)]} \begin{bmatrix} R^+ & S^+ & T^+ \\ R^- & S^- & T^- \end{bmatrix} \begin{bmatrix} V_R \\ V_S \\ V_T \end{bmatrix} \quad (16)$$

The output phases reference voltage are defined as

follows:

$$U_{ref_k} = 220\sqrt{2} \sin\left(\omega_0 t - \frac{2\pi}{3}(k-1)\right) \quad (17)$$

Determining the undulation functions (standard reference functions) that are modulating the virtual intermediate voltage afore mentioned by following expression:

$$U_{cmk} = r \cos(\Phi) \sin\left(\omega_0 t - \frac{2\pi}{3}(k-1)\right) + 1/2 \quad (18)$$

It is well known that the control of the matrix converter ensures each output phase to be switched to each input phase during specified pulses duration within the period of the output voltage. Therefore the pulse period has to be divided into three intervals (Number of output phases) [37-39].

The obtained control signals by phase have binary values, indicating the state of power switches. Fig. 6 shows the time sequence of the switches of one leg during one period of the output voltage. It is clear that the PWM strategy is characterized by two parameters, m and r .

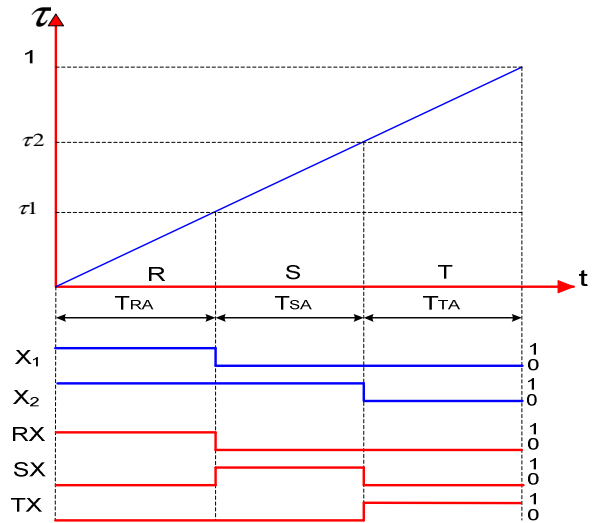

Fig. 6. PWM three intervals that control output phase

The equation of the carrier is defined as follows:

$$U_p = \frac{t}{T} \quad 0 < t < T_p \quad (19)$$

The output binary signals X_i of PWM are defined as follow [17]:

$$X_i = \begin{cases} 1 & \tau_{xi} > U_p \\ 0 & \text{if not} \end{cases} \quad (20)$$

The control signals of the switches of the matrix

converter are obtained using a simple logic as:

$$\begin{cases} T_{A_R} = X_1 \\ T_{B_R} = \overline{X_1} \& X_2 \\ T_{C_R} = X_3 \end{cases} \quad (21)$$

The previous equations are taken into account, so that the reference signals τ_x are defined as follows:

$$\begin{cases} \tau_{x1k} = R^+ U_{cmk} + R^- (1 - U_{cmk}) \\ \tau_{x2k} = S^+ U_{cmk} + S^- (1 - U_{cmk}) \end{cases} \quad (22)$$

Harmonic spectrum and the output voltage V_A by simulation and by implementation in real time (dSpace 1103) are represented in Fig.7.

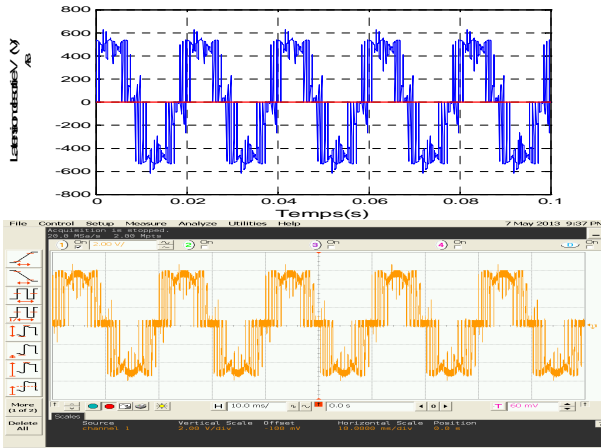

a. The output voltage V_A by simulation and by implementation in real time

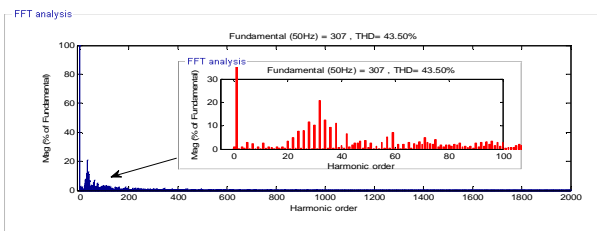

b. Harmonic spectrum of the output voltage V_A

Fig. 7. The output voltage and their harmonic spectrum obtained with the proposed algorithm applied to the [3x5] MC.

5. The [3x5] matrix converter

The converter topology in Fig.8 is characterized by a matrix of fifteen switches (matrix [3x5]); three phases of the network as input are connected to five output phases through bidirectional power switches [39].

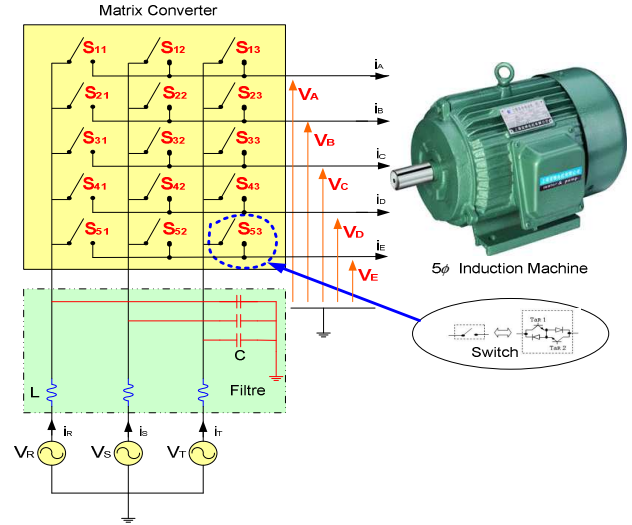

Fig. 8. Schematic diagram of the [3x5] MC.

The model of the matrix converter with middle fictitious circuit is represented as follow:

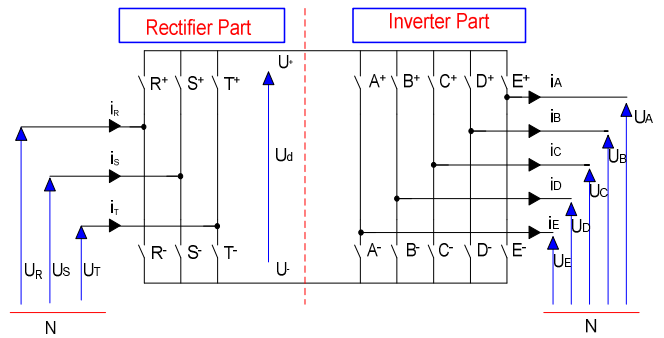

Figure 9. Model of the MC with middle fictitious circuit.

The study of the rectifier part is the same as previously, but the study of the inverter part needs to fulfill the multi-phases topology similarly to equation (15). The link between the middle potential and the output voltages of the matrix converter can be expressed as follows:

$$\begin{bmatrix} U_A \\ U_B \\ U_C \\ U_D \\ U_E \end{bmatrix} = \begin{bmatrix} U_{cm1} & 1-U_{cm1} \\ U_{cm2} & 1-U_{cm2} \\ U_{cm3} & 1-U_{cm3} \\ U_{cm4} & 1-U_{cm4} \\ U_{cm5} & 1-U_{cm5} \end{bmatrix} \begin{bmatrix} U^+ \\ U^- \end{bmatrix} \quad (23)$$

Taking into account the two blocks rectifier - inverter, the matrix $[M_2(t)]$ which allows defining the complete algorithm function of frequency conversion can be presented as follows:

$$\begin{bmatrix} U_A \\ U_B \\ U_C \\ U_D \\ U_E \end{bmatrix} = \underbrace{\begin{bmatrix} U_{cm1} & 1-U_{cm1} \\ U_{cm2} & 1-U_{cm2} \\ U_{cm3} & 1-U_{cm3} \\ U_{cm4} & 1-U_{cm4} \\ U_{cm5} & 1-U_{cm5} \end{bmatrix}}_{[M_2(t)]} \begin{bmatrix} R^+ & S^+ & T^+ \\ R^- & S^- & T^- \end{bmatrix} \begin{bmatrix} U_R \\ U_S \\ U_T \end{bmatrix} \quad (24)$$

The output reference voltage phases are defined as follows:

$$U_{ref_k} = 220\sqrt{2} \sin\left(\omega_0 t - \frac{2\pi}{5}(k-1)\right) \quad (25)$$

Determining the functions of undulation (standard reference functions) that are modulating the virtual middle voltage afore mentioned:

$$U_{cmk} = r \cos(\Phi) \sin\left(\omega_0 t - \frac{2\pi}{5}(k-1)\right) + 1/2 \quad (26)$$

The rest of the equations are the same as the equation (19), (20), (21) and (22) that are presented in the first stage of the [3x3] MC study.

Harmonic spectrum and the output voltage V_A by simulation and by implementation in real time (dSpace 1103) are represented in Fig.10.

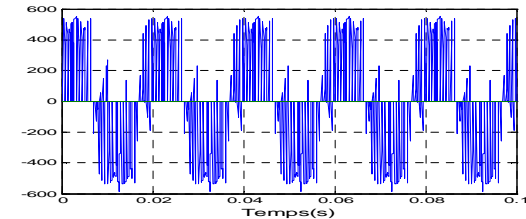
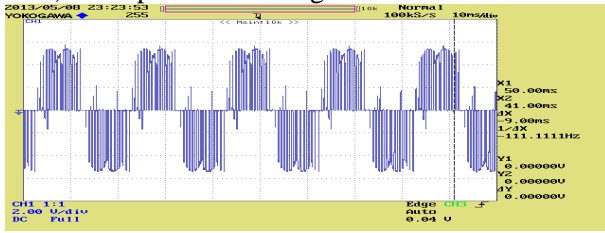

a. The output voltage V_A by simulation and by implementation in real time

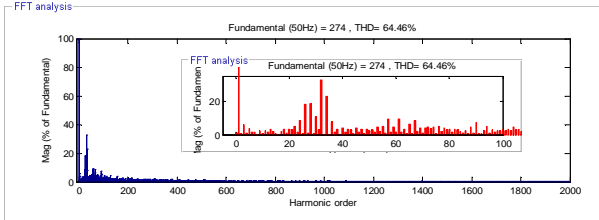

b. Harmonic spectrum of the output voltage V_A

Fig. 10. The output voltage and their harmonic spectrum obtained with the proposed algorithm applied to the [3x5] MC.

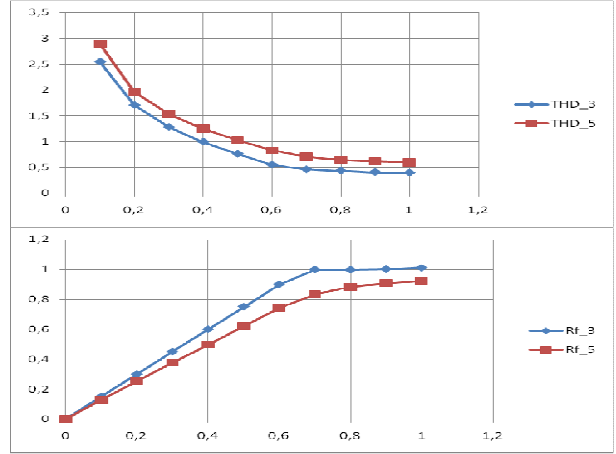

Fig. 11. Characteristics of the THDs and the amplitude ratio relative to modulation index r of each MC.

6. Field Oriented Control

In the early 1970, the appearance of the vector control allowed a considerable increase of dynamic performance of the induction motors (IM) [42]. The aim of the vector control is to obtain a similar dynamic as a DC machine, where torque and flux are decoupled and hence could be controlled independently.

Vector control techniques can be separated into two categories: Direct and Indirect flux vector orientation. Direct field oriented control, published for the first time by Blaschke in his pioneering work in 1972, consists to adjust the flux by a component of the current and the torque by the other component. For this purpose, it is necessary to choose a d-q reference frame rotating synchronously with the rotor flux space vector, in order to achieve decoupling control between the flux and the produced torque. This technique allows to obtain the behaviors of a DC machine [28] [42]. The field orientation is obtained by imposing the condition ($\phi_{dr} = \phi_r$ and $\phi_{qr} = 0$) in the equation.6 to 8. This method requires determining the position θ_e and flux Φ_r whatever the operating conditions. The major difficulty in the realization of the FOC is the determination of the modulus and phase of the flux, because these two parameters are not directly measured.

To determine the position and the flux module, the natural idea is to measure the flux in the machine using additional coils or Hall Effect sensors. This weakens the engine and requires a special construction. Asynchronous motor loses its main advantage is robustness. The model of the machine is often used to determine the position and module of flux.

The speed regulation is reached by an IP corrector type.

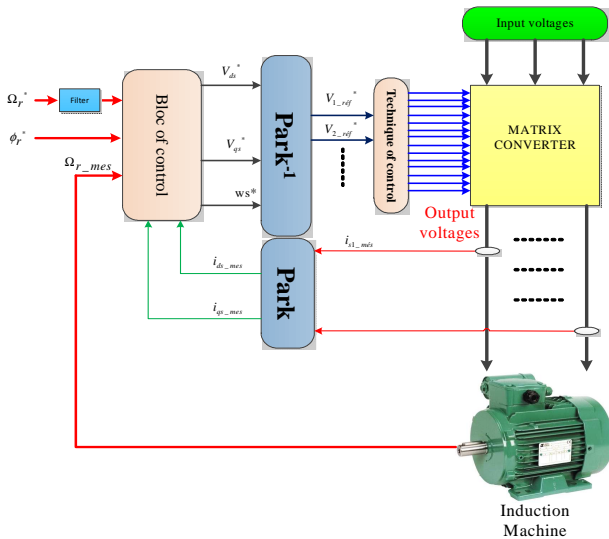

Fig.12 .Synoptic scheme of the direct field oriented control of an induction machine fed by a matrix converter.

7. Simulation and results

To have an overview about the behaviors of the FOC control applied on the three phases and five phase MC- Induction Machine models. The both models are tested under simulation implementation. The input three-phase voltage is a typical three-phase voltage system which is characterized by a magnitude of 220V and a frequency of 50 Hz, the switching frequency is chosen to be 1550 Hz with a modulation index $r=0.8$. The output voltages by simulation and by implementation in real time and their THDs obtained by the applications of the proposed methods are presented in Fig. 7 and Fig. 10. The value of the fundamental voltage for three phase is 307 V which is great than the five phase 274 V, in the same time the value of THDs are 43.50% and 64.46 respectively. In Fig. 6 and Fig. 7 the characteristics of the harmonic spectrum and the characteristics of amplitude ratio relative to modulation index r are presented. From the both curves presented in Fig. 11, It is obvious that the curves of THD has almost the same appearance, whereas the curve Rf_3 phase presenting the voltage output-input ratio shown in fig. 11 has a greater values compared to the curve of five-phases. Comparisons of the performances of the matrix converter -induction motor association controlled by the F.O.C for the both models are shown in Fig.13 and Fig. 14. The following remarks can be deduced:

1- The five phase application has the following advantages in comparison of the three-phases application:

- The speed curve response time dynamics is faster,
- the torque curve has less ripples rate,

- the value of the output voltage of converter is higher,
- Furthermore the amplitude of the output current in five phase is reduced compared to the three-phase (from 4.5 A to 3.5 A) which can prevent deterioration of the windings; use smaller gauge switches (reduce the cost of purchase and maintenance).

2- The two applications has nearly the same advantages:

- where the curves of input voltage and output current has almost a sine waveform,
- When the same disturbance is applied to the both machines, the curves of speed in the two cases have the same behaviors of load compensations (the decrease and increase of the speed due to the variation of the load are quickly corrected by the PI controller).

It is clearly that the voltage is periodic and follows the desired amplitude and frequency.

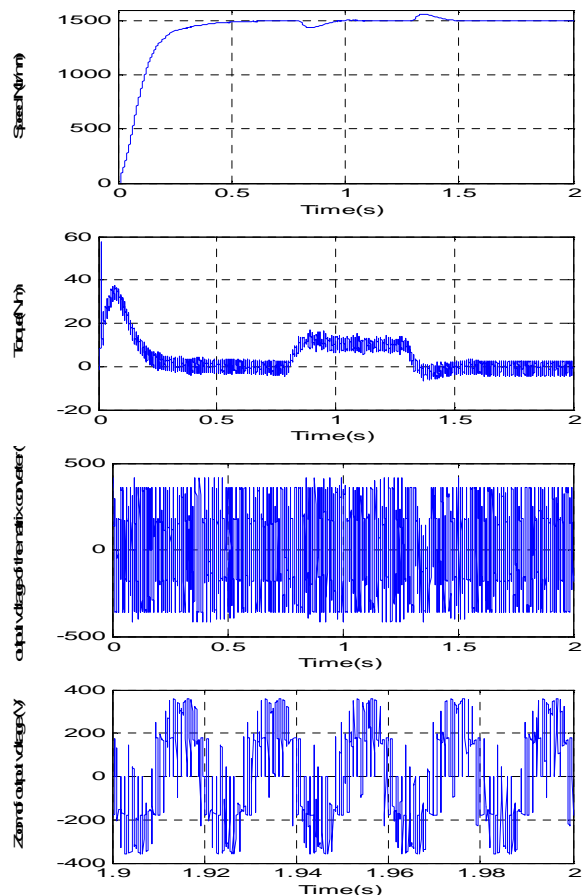

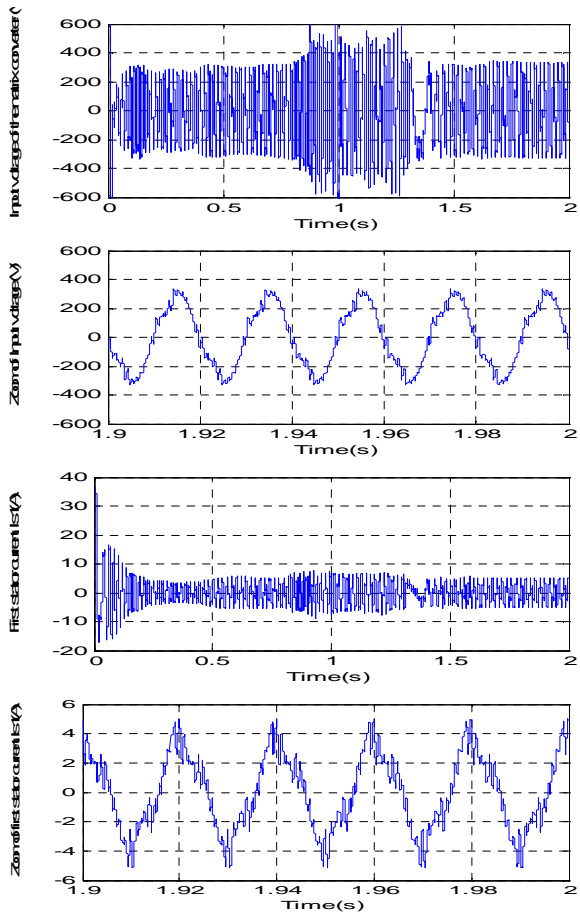

Fig. 13. Simulation results matrix converter [3x3]-induction motor by the F.O.C.

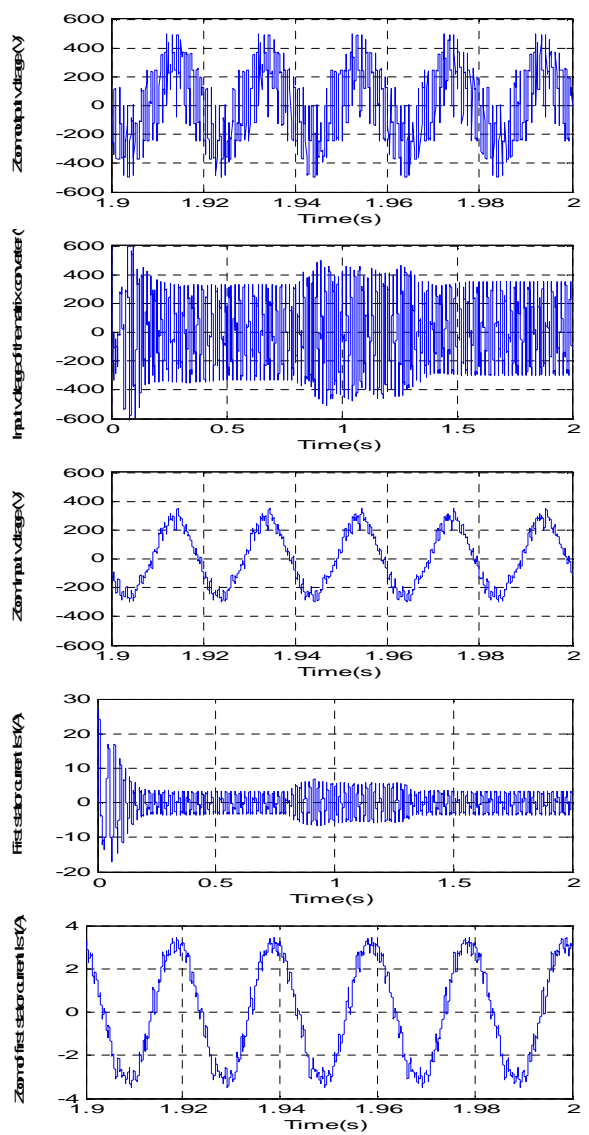
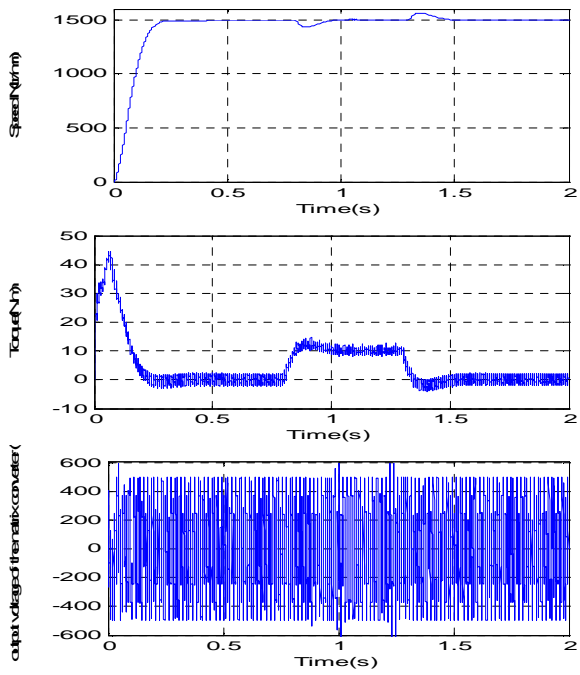

Fig. 14. Simulation results matrix converter [3x5]-induction motor by the F.O.C.

8. Conclusion

In this paper the application of the Field Oriented Control on MC-induction machine association is presented for the following applications:

- Three phases induction machine fed by [3x3] Matrix converter.
- Five phases induction machine fed by [3x5] Matrix converter.

As it can be deduced from the presented study the multi-phases power supply problem is resolved by the arrangement of the second converter [3x5] to avoid the requirement of a power supply with five phases, instead a matrix converter [3x5] can overcome this problem to ensure the feeding of five-phase machine or even more phases.

The obtained results show that, the second system (five phases machine fed by [3x5] Matrix converter) is

better, than the three-phases output matrix converter which can be generalized for more than five phase output. On the other side; the present study shows that the matrix converter [3xn] has some inherent advantages that make this application a very promising solution, especially when it is connected to multi-phases machine to profit mainly from all its benefits in industrial plants applications.

References

1. Nguyen T.D., Lee H.H.: Carrier-based PWM Technique for Three-to-Five Phase Indirect Matrix Converters. In: 37th Annual Conference on IEEE Transactions on Industrial Electronics Society- IECON'11, 2011, pp. 3662–3667.
2. Taheri, A., Rahmati, A. R., Kaboli, S.: Efficiency Improvement in DTC of Six-Phase Induction Machine by Adaptive Gradient Descent of Flux. In: IEEE Transactions Power Electronics, 2012, Vol. 27, no. 3, pp.1552-1562.
3. Levi, E. :Multiphase electric machine for variable speed applications. In: IEEE Transactions on Industrial Electronics, 2008, vol. 55, no. 5, pp. 1893–1909.
4. Fnaiech, M. A., Betin, F., Capolino, G. A., Fnaiech, F.: Fuzzy Logic and Sliding-Mode Controls Applied to Six-Phase Induction Machine With Open Phase. In: IEEE Transactions on Industrial Electronics, 2010, vol. 57, no. 1, pp. 354-364.
5. Williamson, S., Smith, S.: Pulsating torque and losses in Multiphase Induction Machines. In: IEEE Trans on Industrial Application, 2003, vol.39. no.4, pp. 986-993.
6. Riveros J. A., Prieto J., Barrero F., Toral S., Jones M., Levi E.: Predictive Torque Control for Five-Phase Induction Motor Drives. In: - 36th Annual Conference on IEEE Industrial Electronics Society-IECON'10, 2010, pp. 2467 - 2472.
7. Rodriguez, J., Rivera, M., Kolar, J. W., Wheeler, P. W.: A Review of Control and Modulation Methods for Matrix Converters. In: IEEE Transactions on Industrial Electronics, 2012, vol. 59, no. 1, pp.58-70.
8. Empringham, L., Kolar, J., Rodriguez, J., Wheeler, P. W., Clare, J.: Technological issues and industrial application of matrix converters: A review. In: IEEE Transactions on Industrial Electronics, 2013, vol. 60, no.10, pp. 4260-4271.
9. Chai M., Dutta R., Fletcher J.: Space Vector PWM for Three-to-Five Phase Indirect Matrix Converters with d2-q2 Vector Elimination. In: 39th Annual Conference of the IEEE Industrial Electronics Society-IECON'13, 2013, pp. 4937–4942.
10. Yamamoto, E., Uchino, T., Kawaji, M., Kume, T. J., Kang, J. K., Krug, H. P.: Development of MCs and its applications in industry. In: Industrials Electronics Magazine IEEE, 2011, vol.5, no.1, pp. 4-12.
11. Vadillo J., Echeverria J.M., Fontán L., Martínez-Iturralde M., Elósegui I.: Modelling and Simulation of a Direct Space Vector Modulated Matrix Converter using different Switching Strategies. In: International Symposium on Power Electronics- SPEEDAM'08 2008, pp. 944-949.
12. Wheeler, P.W., Rodriguez, J., Clare, J.C., Empringham, L., Weinstein, A.: Matrix Converters – A Technology Review. In: IEEE Transactions on Industrial Electronics, 2002, Vol. 49, no.2, pp. 276 – 288.
13. Wheeler, P. Clare, J., Empringham, L., Apap, M., Bland, M., “Matrix Converters. In: Power Engineering Journal, December 2002, pp. 273 – 282.
14. Sunter S., Clare, J.C.: Development of a Matrix Converter Induction Motor Drive. In: 7th Mediterranean Electro technical Conference IEEE MELECON'94, 1994, vol. 2, pp. 833- 836.
15. Sunter S., Clare J.C.: A True Four Quadrant Matrix Converter Induction Motor Drive with Servo Performance. In: 27th Annual IEEE Power Electronics Specialists Conference, PESC'96, 1996, Vol. 1, no.1, pp. 146–151.
16. Iyer N. P.R.: Carrier Based Modulation Technique for Three Phase Matrix Converters – State of the Art Progress. In: International Conference Computational Technologies in Electrical and Electronics Engineering IEEE - SIBIRCON'10, 2010, pp. 659–664.
17. Huber, L., Borojevic, D.: Space vector modulated three-phase to three-phase matrix converter with input power factor correction. In: IEEE Transactions on Industry Applications, 1995, vol.31, no.6, pp. 1234-1246.
18. Fang, Y.: Study on the control strategies of matrix converter and its control method for doubly-fed adjusting speed system. PhD. dissertation, China University of Mining and Technology, 2006.
19. Fang Y., Tan G., Liu H.: Space Vector Modulated Three-phase to Two-phase Matrix Converter. In: International conference on electrical Engineering, 2009.
20. Aghasi, M., Khaburi, D. A., Faraji, V., Behnia, H.: A Comparative Study on Predictive and ISVM Direct Torque Control Methods for a Doubly Fed Induction Machine Fed by an Indirect Matrix Converter. In: Iranian Journal of Electrical & Electronic Engineering, June 2012, vol. 8, no.2, pp 138-145.
21. Karthik, V., Agarwal, P.: Implementation of SVPWM control on FPGA for three phase Matrix Converter. In: International Journal on Communication- ACEEE'10, July 2010, Vol. 1, No. 2.
22. Wei L., Lipo T.A.: A novel matrix converter topology with simple commutation. In: 36th Industry Applications Conference, Annual Meeting. Conference Record IEEE, Sep-4 Oct 2001, vol.3, pp.1749-1754.
23. Behnia, H., Khaburi, D.A., Aghasi, M., Faraji, V., “Enhanced Direct Torque Control for Doubly Fed Induction Machine by Active Learning Method Using Indirect Matrix Converter”, International Journal of Engineering, IJE , 2012, Vol.6, no.4.
24. Kolar, J.W., Friedli, T., Rodriguez, J., Wheeler, P. W., “Review of three-phase PWM AC-AC converter topologies”, IEEE Transactions on Industrial Electronics, 2011, vol. 58, no.11, pp. 4988–5006.
25. Bauer, J.” Simulation of a Matrix Converter Fed Drive with Sliding Mode Control”, Acta Polytechnica, 2012, Vol. 52, no. 5.
26. Karpagam, J, Kumar. A.N, Chinnaiyan. V.K., “Comparison of Modulation Techniques for Matrix Converter”, IACSIT International Journal of Engineering and Technology, April 2010, Vol.2, no.2.
27. Magzoub M. A., Saad N.B., Ibrahim R.B.: Analysis and Modeling of Indirect Field-Oriented Control for PWM-driven Induction Motor Drives. In: IEEE Conference on Clean Energy and Technology-CEAT'13, 2013, pp. 488-493.
28. Djahbar, A., Mazafu, B., Latroch, M.: Control strategy of three-phase matrix converter fed induction motor drive system. In: IEEE International Workshop on Intelligent Signal Processing, 2005, pp. 104-109.
29. Jisha, L. K., Thomas, A. A. P.: A Comparative study on scalar and vector control of Induction motor drives. In: IEEE, International conference on Circuits, Controls and Communications- CCUBE'13, 2013.
30. Khan, H.:Field oriented control. Application note, Polytechnic Clermont-Ferrand, RENESAS, 2008.
31. Bohari A.A., Utomoa W.M., Harona Z. A., Zina N. M., Sim S.Y., Ariff R. M.: Speed Tracking of Indirect Field Oriented Control Induction Motor using Neural Network. In: Science Direct, International Conference on Electrical Engineering and Informatics-ICEEI'13, 2013.
32. Rezaoui M.M., Nezli L., Mahmoudi M.O.: Study of Output Voltages of a Matrix Converter Feeding a Five AC – Induction Motor Using the Strategy PWM Modulation to Five Intervals. In: Sixth International Conference on Electrical Engineering CEE 2010, Batna, Algeria, Oct. 2010.
33. Rezaoui, M.M., Nezli, L., Mahmoudi, M.O.: Matrix Converter 3x5 with Calculated PWM Strategy for Feeding Induction Motor. In: International Journal of Science and Research (IJSR), July 2013, Vol. 2, no. 7, pp 246-250.
34. Rezaoui M.M., Kouzou. A., Nezli L., Mahmoudi M.O.: Comparative Analysis of PWM Strategies of Venturini and Roy for the Control of a [3x3] Matrix converter for Renewable Energies Sources. In: SSD'13 International Multi-Conference on Signals & Devices, Power Electrical Systems (PES), N0 1569708493, March 2013- Hammamet, Tunisia, published in IEEE July 2013.
35. Rezaoui, M.M., Kouzou, A., Nezli, L., Mahmoudi, M.O.: Comparative Analysis of PWM Strategies of Venturini and Roy for the Control of a [3x3] Matrix converter. In: International Journal of Advanced Renewable Energy Research, 2013., Vol.2, no.2, pp. 681-688

36. Abdel-Rahim, O., Abu-Rub. H., Kouzou. A.: Nine to three phase direct matrix converter with model predictive control for wind generation system. In: Science direct, Energy Procedia, 2013, Vol. 42, pp. 173-182.
37. Toliyat, A. H., Huangsheng. X., Petersen, L. J.: Five-Phase Induction Motor Drives with DSP-Based Control System. In: Electric Machines and Drives Conference IEEE, 2001, pp. 304-309.
38. Semail E., Levi. E., Bouscayrol A., Kestelyn X.: Multi-Machine Modeling of Two Connected Series 5-Phase Synchronous Machines: Effect of Harmonics on Control. In: European Conference on Power Electronics and Applications IEEE, 2005, pp. 10.
39. Rezaoui, M.M., Nezli, L., Mahmoudi, M.O., Kouzou, A., Abu-Rub, H.: A Modified PWM three intervals Control for a Matrix converter in Real Time. In: Archives of Control Sciences, ACS'14, 2014, vol. 24, (LX), no 1, pp. 85-98.
40. Bech M.M., alborg A., Pedersen J.K., Blaabjerg F.: Field-oriented control of an induction motor using random pulse width modulation. In: 15th Applied Power Electronics Conference and Exposition IEEE-APEC'00, 2000, vol. 2.
41. Liu, T.H., Fu, J. R., Lipo, A. T.: A strategy for improving Reliability of Field-Oriented Controlled Induction Motor Drives. In: IEEE Transactions on Industry application, 1993, vol. 29, no. 5.
42. Boulghasoul, Z., Elbacha, A., Elwarraki, E., Yousfi, D.: Combined Vector Control and Direct Torque Control an Experimental Review and Evaluation. In: International Conference on Multimedia Computing and Systems ICMCS'11, Ouarzazate Morocco, 7-9 April 2011, pp.1-6.