

An Advanced SMPS Converter to Track the Maximum Power from the Thermoelectric Generator

SAIDARAO.K¹(MTECH STUDENT) M.SRIKANTH²(ASST. PROFESSOR)

KL University, Green fields Vaddeswaram, Guntur (Dist),AP,India.

09030212324,saidarao4@gmail.com, 09490036376, sikanth_ee250@kluniversity.in

Abstract— In this paper, an advanced SMPS converter to track the maximum power from the thermoelectric generator is presented. Generally the Thermoelectric generator (TEG) typical efficiency is 5% - 8%. Also, Internal Combustion Engine (ICE) was vanishing up to 70% of the energy that can be created, largely through heat. As fuel budget becomes more significant for the auto industry each year and with the passing of gradually strict guidelines, car manufacturers had an alert eye on a long-standing concept known as the Seebeck effect. Here, in our paper an Advanced SMPS converter is used to improve the overall efficiency of TEG by 95.2%. An innovated Open-circuit MPPT technique is used to harvest the energy from the TEG. Implementing this concept in auto industry, might lessen the fuel consumption by 5%. The proposed circuit was simulated in Matlab Simulink environment.

Keywords—Thermo electric generator (TEG); MPPT; DC-DC; Advanced SMPS Converter;

1. Introduction

All mechanical systems produce valuable heat energy most of the time. Which is just flung away, or other term it is called loss. But the thermoelectric materials hailed as the solution to reduce this energy problem. They can convert the heat into working electricity. This type of electricity generated is called thermoelectric generators (TEG) ; this type power generation they don't need any moving parts.

It's a statistic a car engine (ICE) which generates almost 70% of the heat energy released[4]; the turbines that generate maximum of the world's electrical power convert only about 1/3 of their heat energy into electricity. Surprisingly, this energy is "wasted" like universally. Or, more exactly, finally that energy is unused [5].

The output of TEGs depends upon a temperature difference to "drive" that device, so one side needs to be cold and the other side hot. The electrons are move more energetically at hot side due to that temperature difference. So they are move towards to the cooler side. The colder side electrons are moving too slowly. From this movement generates the electrical energy. This phenomenon is called as the Peltier-Seebeck effect. This effect is invented in 19th Century and discoverer by two great scientists: Athanase Peltier Jean Charles and Thomas Johann Seebeck. Seekbeck presented a voltage

that can be generated by connecting two dissimilar conductor materials with the temperature difference between them. Peltier's participation was the temperature difference between that junctions of conductors when a current is useful. Also further outcome from, Lord Kelvin confirmed that developed voltage can be depended on the size of two temperatures. So that, from those together effects says that the right materials are connecting together in that incidence of an electrical energy can be generated from heat energy of temperature difference. If the temperature difference is more, then more electrical power can be generated from those materials.

So major challenge is not finding the right material for that effect. Those materials are having low thermal conductivity but with high Peltier Effect conductivity is required. In fact, the TEG's having the slightly exotic-sounding (Bi₂Te₃) bismuth telluride this type of material at 250°C have 4% efficient. For high temperatures we need to use germanium and silicon. Those materials are having less efficiency that converts the heat energy into electrical energy. Thankfully, the scientists are invented "nanosculpture" just recent years, so that this type of materials can improve the flow of electrons and permissive of flow of heat. This effect leads to the improvement in the efficiency of TEG's.

The difficult task is how we define the efficiency of thermoelectric generator (TEG). This is a challenging task to find the thermoelectric materials. Consider an area at UK scientists of the National Physical Laboratory at London they are more concentrated towards finding the efficient measurement of those materials and compare the performance of TEG's.

Definitely, TEGs are attached to the exhaust pipe outside surface of vehicle, that particular area generates the heat energy. The hot side of the TEG's can be connected at high-temperature gases passing though, while the water-filled pipes are connected in cold side of the TEG's, or even the motion of car creates the air movements, then to remove heat of material. Early this system can be produced about 600W [6], by implementing this in an auto industry the fuel consumption can be reduced by 5%, so they have a lot of prospective. Chevrolet, BMW and Volkswagen are all

mounting TEG systems, so this system will be seen on cars soon.

And implementation of thermoelectric generator is very small amount of saving fuel in individual, but thought out the world we can save the massive amount of fuel, from left-over energy.

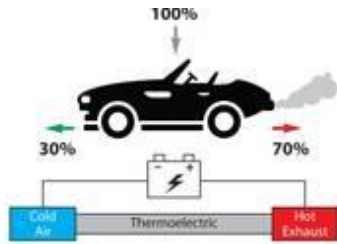

Fig 1: Waste of Heat energy from vehicles.

The TEG's of temperature difference is directly proportional to magnitude of open-circuit voltage, as like that solar cells an appropriate number of TEGs can be connected in parallel or series in order to reach desired levels of current and voltage. Power electronic converters are used to every time interface with TEGs to the desired output. We choose the converter depends up on the input and output voltages. As a while for connection to a 12-V automotive battery a Buck or Buck-Boost or advanced SMPS converters used to interface with TEG's. This type of work uses a synchronous Self-lift Converter to get a wide range of input voltage and consequently crop power from the TEGs and also depending upon the operating temperature of its.

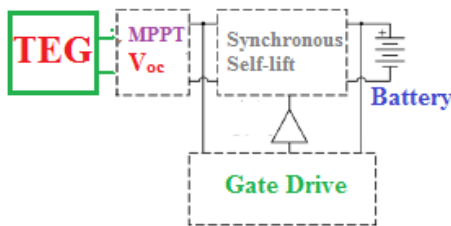

Fig: 2 Block diagram proving the fundamental structure of the suggested system.

In the literature, the mostly used MPPT[1]-[3] methods for TEGs a Perturb & Observe (P&O) and the incremental conductance method (INC). These MPPT methods are originally developed for PV systems only, in which the relationship in between voltage and current values. According to theoretical values of TEGs, electrical characteristic are linear.

$$V_{mp} = V_{oc}/2 \text{ and } I_{mp} = I_{sc}/2$$

Where the V_{mp} and I_{mp} are the maximum power point of voltage and current, I_{sc} is the short-circuit current and V_{oc} is the open-circuit voltage of the TEG's. MPPT [4] methods are depending upon measure the

relation between either short-circuits current or the open-circuit voltage, those are provided more number of advantages over the regular methods:

- 1) We concentrate on the only one parameter either open circuit voltage or short circuit current;
- 2) The iterations of this method are less required;
- 3) Steady-state oscillation are not provided like (P&O) or error (INC).

We suggest an advanced open-circuit voltage measurement technique, described and analyzed in next Section where normal switching of converter is accepted, this circuit can have the high efficiency compared to previous discussed converters.

The above Fig 1, shows the proposed system block diagram, the self-lift converter input is connected to the TEG, by using gate driver circuits we can drive the MOSFET switches of converter and TEG. The load of the circuit as a rechargeable battery is represented by a battery.

2. Thermoelectric generator

A. Seebeck effect

Thermoelectric effect is nothing but to convert the heat energy into electrical energy. The energy conversion can be easily discussed with the help of below diagram Fig: 3. the thermoelectric effect can be measured as a circuit formed with two different conductors which are connected thermally in parallel but connected in series electrically, if the junction's p and n type materials maintain with different temperatures T_1 and T_2 . When $T_1 > T_2$ a electromotive force (emf), voltage is build up between the output conductors that can be expressed as

$$V = \alpha(T_1 - T_2) \text{ or } \alpha = \frac{V}{\Delta T} \quad (1)$$

In above equation ' α ' is the seebeck co-efficient. This co-efficient is not deviating with a small temperature difference. Even though by pact α is represented as the seebeck coefficient, sometimes ' S ' is also used the seebeck coefficient, this one can be devoted to as the thermal power.

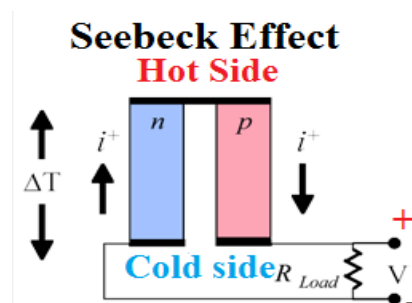

Fig: 3 Seebeck Effect

B. Peltier Effect

In this effect the opposite situation reflects with an external emf source applied across load (Battery) a current 'I' flows in a clockwise sense around the circuit then a rate of heating 'q' happens at one junction between p and n and a rate of cooling -q happened at the other side. The ratio between 'I' and 'q' defines the peltier coefficient given by

$$\Pi = I/q \tag{2}$$

If p is hot side and n is cold side then we get positive Peltier coefficient and it is measured in watts per ampere or volts.

C. Thomson Effect

The thermoelectric effect and Thomson effect expressed the rate of generation of reversible heat and the resultant current is passing through a single conductor is depending up on the temperature difference ΔT , the resultant temperature difference is providing very small,

$$q = \beta I \Delta T \tag{3}$$

Where β is the representation of Thomson coefficient. The Thomson coefficient have the measurement unit is same as the seebeck coefficient V/K.

D. TEG's Electrical Characteristics

The electrical characteristics of 2 TEG's under study are characterized separately at different temperatures gradients ΔT : 100 °C, 150 °C, and 200 °C. Every test was performed with 1.25MPa of mechanical pressure onto each TEG,[10]. The below Fig: 4, shows the power versus current and output voltage of TEG's

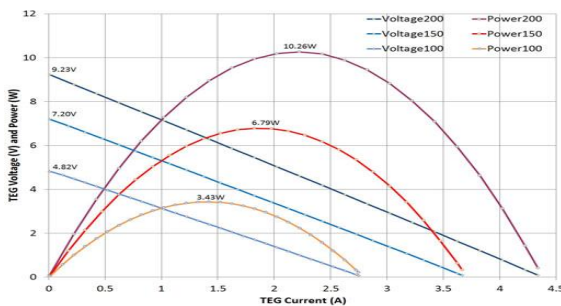

Fig: 4 Electrical characterization of TEG.

E. MPPT Method

In this paper, concentrate on the maximum power point technique. Generally TEG has low efficiency so need to implement on this. It is observed of Electrical characteristics of TEG; maximum power can be achieved at half of the open circuit voltage. So maintain the every time that half of the open circuit voltage then gets maximum power from the TEG. This is the challenging task of maintain that voltage. For that we design a DC-DC snubber circuit. By using this circuit we can maintain every time half of the open circuit voltage. The open- circuit voltage of TEG's set at a load half of the open-circuit voltage (V_{oc}). In this method, the converter can be disconnected from the TEG and generally requires an input capacitor. The input capacitor of converter has to be charged up to open-circuit voltage (V_{oc}) during that time output power is null collected. The input capacitor is chosen in the order of tens of microfarads, so as to maintain the RMS current which means the output capacitor may need hundreds of microseconds charged up to reach the open-circuit voltage (V_{oc}), and this one depends on the internal resistance (R_{int}). Sometimes disconnect the TEGs from the converter; an extra series switch is needed. This series switch needs to be in continuous conduction period for longer time, for this required high side gate drive circuit. An additional I^2R losses are presented in switch with ON time. And switch ON time is interrupting the normal operation of converter. The V_{oc} measurement is taken in every time of switch ON.

3. Self-lift Converter

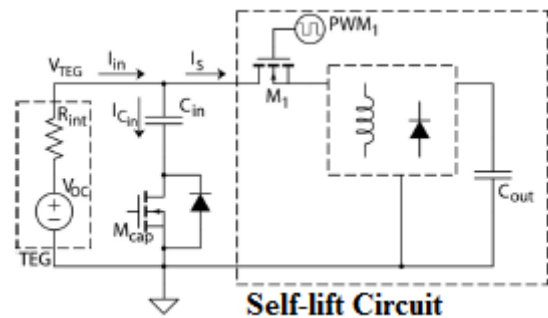

Fig: 5 schematic diagram of proposed MPPT technique.

The Self-lift circuit can perform step-down and step-up DC-DC [8] conversion. This can be shown in the corresponding figures.

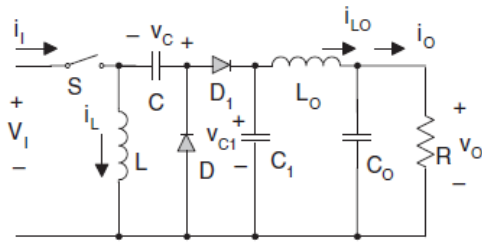

Fig: 6 Self-lift Converter

Self-lift circuit has the capability of lift the input voltage at C_1 and D_1 is enough. As a lift voltage is further into the circuit. The function of Capacitor C_1 is lifting the capacitor voltage C_1 up to input voltage V_{in} . The capacitor across Current is $i_{C1}(t) = \delta(t)$ is like exponential function. At that movement the capacitor have a large value of power.

Circuit Description

When switch S is on, the source current $i_{in} = i_{L1} + i_{L2}$. At this time Inductor L_1 is charging condition from the input. In the time being inductor L_2 takes the energy from capacitor C , as well as input. This time both inductor currents are increase. When switch S is off, input current $i_{in} = 0$. The inductor Current i_{L1} streams through the free-wheeling diode D , and Charge the capacitor C . the charging energy takes from Inductor L_1 . In the time being the inductor current i_{L2} moves through the $(C_0 - R)$ and freewheeling diode D is continuous mode itself [7]. Both the inductors currents i_{L1} and i_{L2} are decrease in this mode. In order to analyse the circuit working play, the equivalent circuits in switch-on and - off states are shown in the bellow[9] Figures,

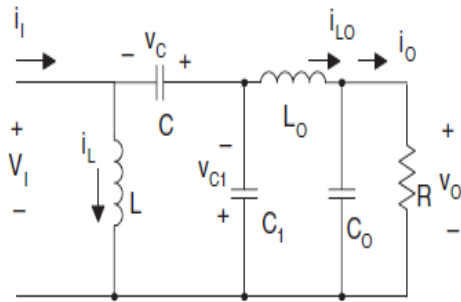

Fig: 7 Circuit diagram when S is ON.

Actually, the variations of currents i_{L1} and i_{L2} are small so that $i_{L1} \approx I_{L1}$ and $i_{L2} \approx I_{L2}$.

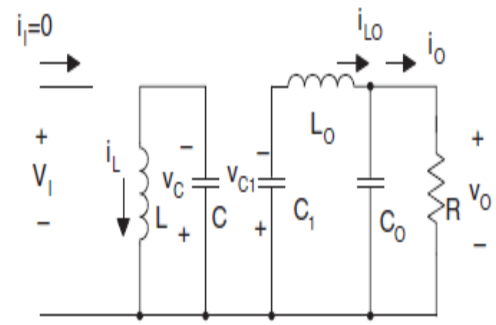

Fig: 8 Circuit diagram when S is OFF.

The charge on capacitor C increases during switch off:

$$Q_+ = (1 - k)T I_{L1} \quad (4)$$

It decreases during switch-on:

$$Q_- = kT I_{L2} \quad (5)$$

From the above (4) and (5) equations

In a whole period investigation, $Q_+ = Q_-$. Thus,

$$I_{L2} = \frac{1-k}{k} \times I_{L1} \quad (6)$$

Since capacitor C_0 performs as a low-pass filter, the output current

$$I_{L2} = I_o \quad (7)$$

These two Equations (6) and (7) are available for all positive output of Self-lift Converter.

The switch is ON period source current is $i_I = i_{L1} + i_{L2}$, and switch is OFF condition $i_I = 0$

Thus, the average input current is

$$I_I = k \times i_1 = k(i_{L1} + i_{L2}) = k(1 + \frac{1-k}{k})I_{L1} = I_{L1} \quad (8)$$

Therefore, the output current is

$$I_o = \frac{1-k}{k} I_I \quad (9)$$

Hence, output voltage is

$$V_o = \frac{k}{1-k} V_I \quad (10)$$

The voltage transfer gain continuous mode is

$$M_E = \frac{V_o}{V_I} = \frac{k}{1-k} \quad (11)$$

Current across inductor $iL1$ increases and it's supplied by input voltage V_{in} when the switch is ON condition. And its decrease to $-V_c$ at switch is OFF condition. Therefore,

$$kTV_I = (1-k)TVC$$

So that the capacitor C across average voltage is denoted by

$$V_C = \frac{k}{1-k} V_I = V_O \quad (12)$$

During switch-on period, the voltage across capacitor $C1$ are equal to the source voltage plus the voltage across C . Since we assume that C and $C1$ are sufficiently large [8],

$$V_{C1} = V_1 + V_C$$

Therefore,

$$V_{C1} = V_1 + \frac{k}{1-k} V_1 = \frac{1}{1-k} V_1 \quad (13)$$

$$V_O = V_{CO} = V_{C1} = \frac{1}{1-k} V_1 \quad (14)$$

Theoretical Analysis of MPPT Efficiency

Let us assume that the TEG's output is setting the correct maximum power point of MPPT converter, so that the input capacitor average voltage is $V_{MP} = V_{OC}/2$. Considering a small voltage ripple on C_{in} , during toff, C_{in} is charged by the current $I_{Cinoff} = V_{OC}/2R$, in capacitor OFF time the resistance is $R = R_{int} + ESR$, sum of series resistance (ESR) of the input capacitors equal to the TEG's internal resistance. Then calculate the RMS of I_{Cin} , off as

$$I_{Cin\ off\ RMS}^2 = k' I_{in}^2 = \frac{k' V_{oc}^2}{4R^2} \quad (15)$$

From the above equation k is the duty ratio of the converter and $k' = (1 - k)$.

The input capacitors low-side switch M_{cap} in series is dissipated power is

$$P_{Mcap} = r_{on} I_{Cin\ RMS}^2 \quad (16)$$

Let us now consider the TEG's can supply power to converter at M_{cap} switch is open. Because $M1$ is OFF and the TEG's go to the open circuit current cannot flow into C_{in} . During switch is ON T_{on} , the TEG's of internal

resistance is limits the amount of current, and M_{cap} is forced into conduction so that C_{in} required the additional current by the chosen converter and somewhat discharge condition.

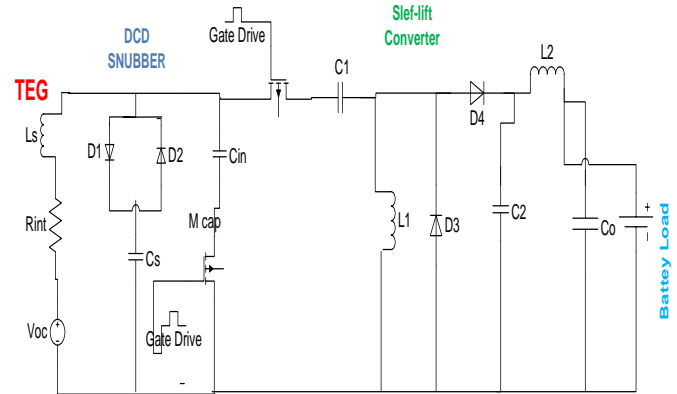

Fig: 9 Schematic diagram of proposed circuit.

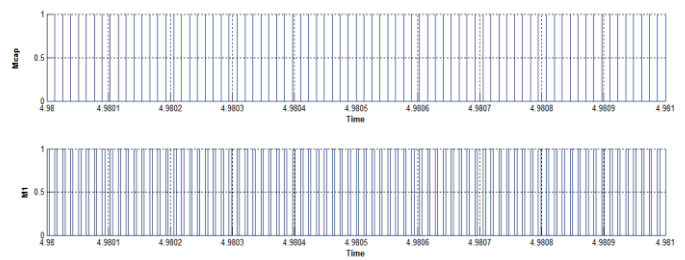

Fig: 10 Switching Gate pulses

The proposed circuit was running at 78 kHz. And set duty ratio of self-lift circuit according to desired the battery voltage (V_b) at the output portion. First measure the open-circuit voltage (V_{oc}) of TEG, and then calculate the PWM's duty ratio using the ideal conditions [11]. And digital control circuit can be measure the input voltage of TEG, and adjust the duty cycle of high side switch of converter maintain

$$V_{in} = \frac{V_{oc}}{2}$$

In this system, the converter deals with changes in the battery voltage and reduces parasitic effects. Fig 9 and Fig 10 show schematic diagram of proposed circuit and switching gate pulsed. The buck-boost converter efficiency is 92.6% [10]. In this paper introduced an advanced DC-DC converter for track the maximum power from the TEG. Using Self-Lift converter can get 95.2% of electrical efficiency.

Table 1

Comparison between buck-boost [10] and self-lift converter electrical efficiency connected in series with 6Ω resistor

S.no	Converter	Vin (V)	Iin (A)	Pin (W)	Pout (W)	μelec (%)
1	Buck-Boost	13.5	2.25	30.38	28.13	92.6
2	Self-lift	11.93	2.56	30.6	29.14	95.2

4. SIMULATION RESULTS

The proposed circuit was simulated in MATLAB Simulink environment with resistive load. The output current and voltage waveforms of circuit are show in bellow Fig 11 and Fig 12. The same circuit was connected to 10Ah rechargeable battery and Fig 13, Fig 14 and Fig 15 show the waveforms of SOC, charging current and voltage of rechargeable battery.

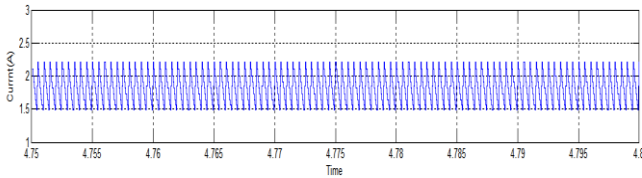

Fig: 11 Output current wave form with resistive load

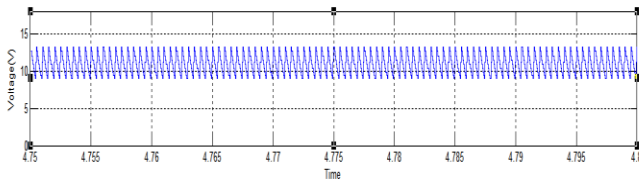

Fig: 12 Output Voltage waveform with resistive load

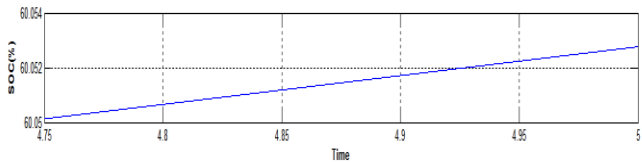

Fig: 13 Output SOC of Rechargeable Battery

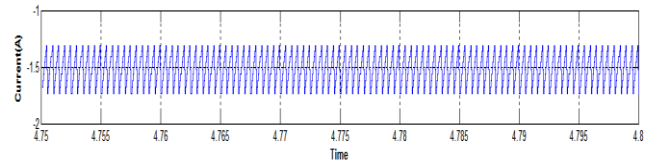

Fig: 14 Charging current of Rechargeable Battery

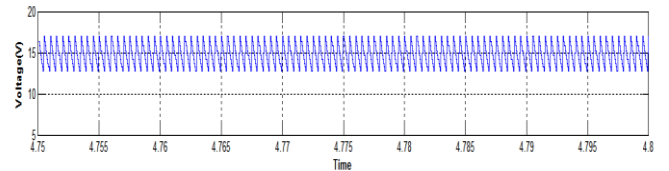

Fig: 15 charging voltage of Rechargeable Battery

The value of input inductor is choosing depending on the peak current ripple. The value of output capacitor is based on RMS value of current. This MPPT technique was implemented for buck-boost [10] converter, at that time got converter electrical efficiency 92.6%. But same technique is applied to Self-lift converter got 95.2% of converter efficiency.

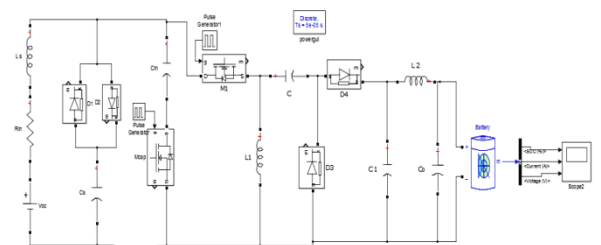

Fig: 16 Simulation diagram of proposed circuit

5. EXPERIMENTAL RESULTS

The proposed DC-DC converter was tested in laboratory. Take the TEG's from the manufactures from china item code is SXR1053417690471ZL are taken. This item open-circuit voltage at temperature 100⁰ c is 4.8V and 669mA. To achieve the required output voltage for 13.5v as open-circuit voltage connected 3modules in series. And circuit running with 78 kHz switching frequency. The switching gate pulses are generated by using arduino uno. The N-Mosfet s used as switches IPD036N04L, as series capacitor and converter switch.

The proposed converter electrical efficiency was tested with 6ohm resistor load. When that point observe 95.2%. And results are obtained detailed in Table 1. Remaining converter elements are taken as mentioned in bellow table.

S.No	Parameter	Rating
1	Inductor Ls	2.25
2	Internal Resistance	2.56
3	Series capacitor Cs	440nF
4	Input capacitor Cin	440nF
5	C1	100μF
6	L1	470μH
7	C2	1μF
8	L2	470nH
9	Co	145μF

Table 2 Circuit parameters selection.

In study state operation of MPPT converter, the no of TEG's are connected in series and get values mentioned in below table.

ΔT (°C)	Exp Max Power		MPPT Converter		
	I_{MP} (A)	P_{max} (W)	I_{MPPT} (A)	P_{MPPT} (W)	P_{var} (%)
100	1.38	10.09	1.33	10.07	0.15
150	1.84	19.88	1.84	19.89	0.00
200	2.17	30.06	2.09	30.02	0.14

Table 3 Converter output power.

The procedure given below to find the theoretical power calculation from the converter is

1) Find the series connected TEG's open-circuit voltages. $V_{oc\ s}=V_{oc1}+V_{oc2}+V_{oc3}$.

2) Calculate the theoretical value for maximum power

$$I_{MP} = \frac{V_{oc\ s}}{2(R_1 + R_2 + R_3)}$$

3) Calculate the maximum power $P_m = V_m * I_m$

4) Calculate the actual power produce TEG, from the mathamatical formulas 2% acuracy was obtained compared with theoretical.

Fig. 17 shows an experimental switching transient condition when take one TEG module is used. Due to the resistance, capacitance and inductor are present in the circuit, the nature of inductor when V_{TEG} reaches V_{MAX} that current can get decreasing and after maintain constant due to open circuit voltage.

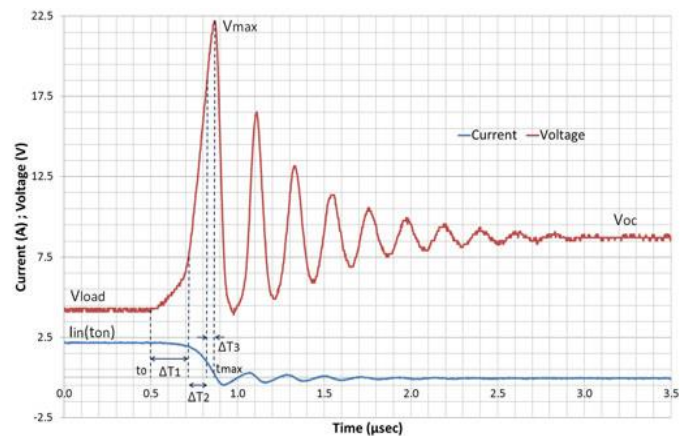

Fig17 voltage and current at load operating condition switching transient of TEG.

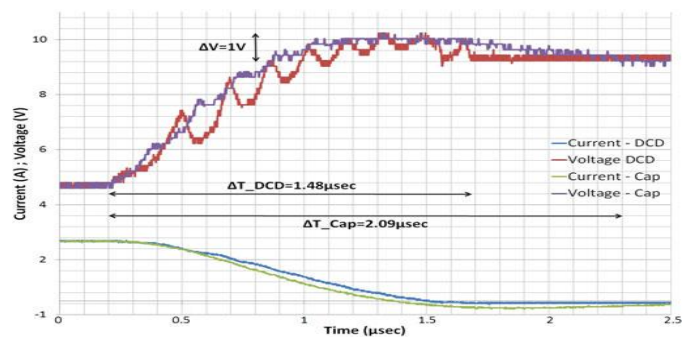

Fig 18 Experimental results comparison with TEG's current and voltage at switching transient operation.

Fig 18 shows experimental results with TEG's current and voltages. When using capacitor in DCD snubber circuit in across with TEG, then maintain half of the open-circuit voltage of TEG and clearly explained in 3rd chapter.

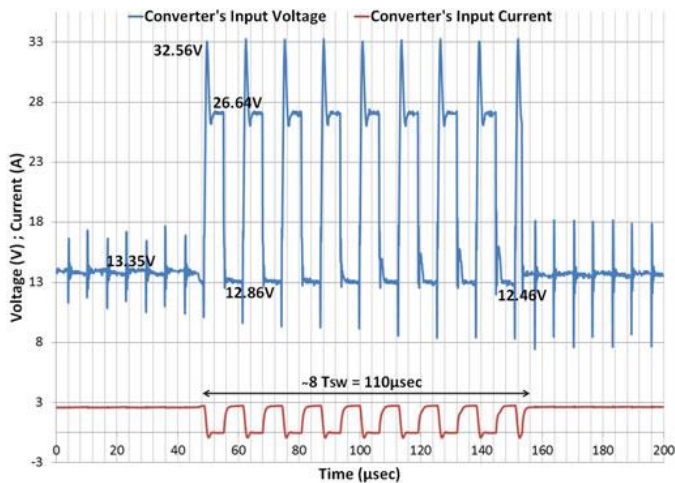

Fig 19 Proposed converter current and voltage measured at open-circuit voltage.

Fig 19 shows converter voltage and current measured at open circuit voltage of TEG. The converter initially running with 13.5V, 2.25A at input side. After 45µsec M_{cap} switch is open, and then the input voltage goes to open-circuit voltage V_{oc} . And all are explained in previous chapter. And the circuit outputs are 11.93V, 2.56A respectively. And Fig 20 shows converter input voltage after open-circuit voltage.

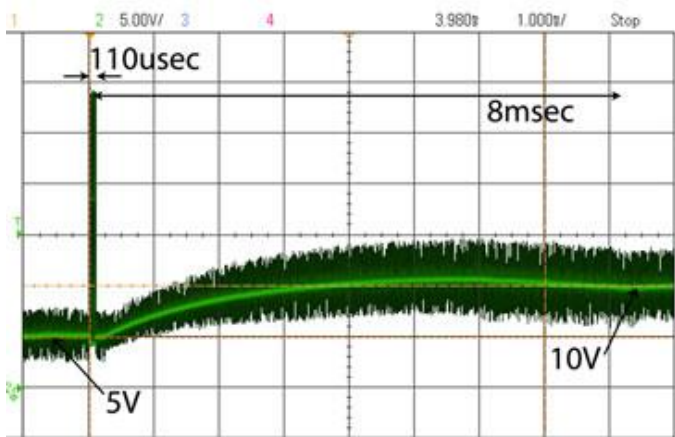

Fig 20 converter input voltage after reaches open-circuit voltage.

6. CONCLUSION

This paper proposes an advanced SMPS DC-DC converter is called as Self-Lift converter. Nowadays increasing the global warming and depletion of fossil fuels need to concentration on renewable energy sources.

All the vehicles release the valuable energy in the form of heat. In auto industry, this heat energy which is wasted is utilized using TEG. In order to obtain maximum power from TEG, advanced DC-DC self-lift converter is proposed. This proposed converter exhibits improved characteristics over the convectional Buck-Boost converter in term of efficiency.

References

1. Journal of Electrical Engineering : Volume 14 / 2014 - Edition : 4, Low cost and high efficiency experimental MPPT based on Hill Climbing: Author: Hassan abouovaida,
2. Journal of Electrical Engineering: Volume 14 / 2014 - Edition: 3 Combination of RCC MPPT and Backstepping controler to design a standard continuous source (12V-24V) supplied by a PV panels, Authors: hassan abouobaida.
3. Journal of Electrical Engineering: Volume 6 / 2006 - Edition: 1: A MLD model development of a boost converter, Authors: Mihaela Sbarciog,Robin De Keyser.
4. D. Rowe and G. Min. (1998, Jun.). Evaluation of thermoelectric modules for power generation. J. Power Sources [Online]. 73(2), pp. 193–198. Available: <http://linkinghub.elsevier.com/retrieve/pii/S0378775397028012>
5. Thermoelectric Generators – TEGs Thu, 9th Feb 2012 Turning waste heat into electrical energy. Available : “<http://www.thenakedscientists.com/HTML/articles/article/thermoelectric-generators/>”
6. Germany: Siemens researches thermoelectric generators By: Automotive World in Analysis, Powertrain Analysis, Suppliers Analysis October 24, 2012 Availble : <http://www.automotiveworld.com/analysis/96679-germany-siemens-researches-thermoelectric-generators/>
7. Six self-lift DC-DC converters, voltage lift technique Fang LinLuo Industrial Electronics,IEEE Transactions on Volume:48,Issue:6DOI:10.1109/41.969408 Publication Year:2001,Page(s):1268-1272
8. M. Zhu and F. L. Luo, “Implementing of developed voltage lift technique on SEPIC, Cuk and double-output dc-dc converters,” in Proc. 2nd IEEE Conf. Ind. Electron. Appl., ICIEA, China, May 2007, pp. 674–681
9. J.A.Morales-Saldana, E. E. C. Gutierrez, and J. Leyva-Ranos, “Modelling of switch-mode dc-dc cascade converters,” IEEE Trans. Aerosp. Electron. Syst., vol. 38, no. 1, pp. 295–299, Jan. 2002

10. Maximum Power Point Tracking Converter Based on the Open-Circuit Voltage Method for Thermoelectric Generators Andrea Montecucco, Student Member, IEEE, and Andrew R. Knox, Senior Member, IEEE

11. Journal of Electrical Engineering: Volume 15 / 2015 - Edition: 1, Design and implementation of generalized proportional integral Controller for Buck converter. By L.Maheswari, S.Vijayalakshmi